

Luna HSM Installation Guide



THE
DATA
PROTECTION
COMPANY

Document Information

Product Version	6.0
Document Part Number	007-011329-007
Release Date	29 May 2015

Revision History

Revision	Date	Reason
A	29 May 2015	Initial release.

Trademarks

All intellectual property is protected by copyright. All trademarks and product names used or referred to are the copyright of their respective owners. No part of this document may be reproduced, stored in a retrieval system or transmitted in any form or by any means, electronic, mechanical, chemical, photocopy, recording or otherwise without the prior written permission of SafeNet, Inc.

Acknowledgements

This product includes software developed by the OpenSSL Project for use in the OpenSSL Toolkit.
(<http://www.openssl.org>)

This product includes cryptographic software written by Eric Young (eay@cryptsoft.com). This product includes software written by Tim Hudson (tjh@cryptsoft.com).

This product includes software developed by the University of California, Berkeley and its contributors.

This product uses Brian Gladman's AES implementation.

Refer to the End User License Agreement for more information.

Regulatory Compliance

This product complies with the following regulatory regulations. To ensure compliancy, ensure that you install the products as specified in the installation instructions and use only SafeNet-supplied or approved accessories.

USA, FCC

This device complies with Part 15 of the FCC rules. Operation is subject to the following two conditions:

- (1) This device may not cause harmful interference, and
- (2) This device must accept any interference received, including interference that may cause undesired operation.

This equipment has been tested and found to comply with the limits for a "Class B" digital device, pursuant to part 15 of the FCC rules. These limits are designed to provide reasonable protection against harmful interference in a residential installation. This equipment generates, uses and can radiate radio frequency energy and, if not installed and used in accordance with the instructions, may cause harmful interference to radio communications. However, there is no guarantee that interference will not occur in a particular installation.

If this equipment does cause harmful interference to radio or television reception, which can be determined by turning the equipment off and on, the user is encouraged to try to correct the interference by one or more of the following measures:

- Reorient or relocate the receiving antenna
- Increase the separation between the equipment and receiver
- Connect the equipment into an outlet on a circuit different from that to which the receiver is connected
- Consult the dealer or an experienced radio/TV technician for help
- Changes or modifications not expressly approved by SafeNet could void the user's authority to operate the equipment.

Canada

This class B digital apparatus meets all requirements of the Canadian interference- causing equipment regulations.

Europe

This product is in conformity with the protection requirements of EC Council Directive 2004/108/EC. Conformity is declared to the following applicable standards for electro-magnetic compatibility immunity and susceptibility; CISPR22and IEC801. This product satisfies the CLASS B limits of EN 55022.

Disclaimer

SafeNet makes no representations or warranties with respect to the contents of this document and specifically disclaims any implied warranties of merchantability or fitness for any particular purpose. Furthermore, SafeNet reserves the right to revise this publication and to make changes from time to time in the content hereof without the obligation upon SafeNet to notify any person or organization of any such revisions or changes.

We have attempted to make these documents complete, accurate, and useful, but we cannot guarantee them to be perfect. When we discover errors or omissions, or they are brought to our attention, we endeavor to correct them in succeeding releases of the product.

SafeNet invites constructive comments on the contents of this document. Send your comments, together with your personal and/or company details to the address below.

Contact Method	Contact Information
Mail	SafeNet, Inc. 4690 Millennium Drive Belcamp, Maryland 21017 USA
Email	techpubs@safenet-inc.com

CONTENTS

PREFACE	About the Installation Guide	7
Customer Release Notes		7
Audience		7
Document Conventions		8
Notes		8
Cautions		8
Warnings		8
Command Syntax and Typeface Conventions		8
Support Contacts		9
CHAPTER 1	Luna SA Hardware Installation	11
Luna SA Required Items		12
SafeNet Luna PED?		14
Additional Options?		16
Installing the Luna SA Hardware		18
Installation Notes		18
Installing the Luna SA Hardware		18
CHAPTER 2	Luna PCI-E Hardware Installation	22
Will Luna PCI-E work with host computer/server XYZ ?		22
Luna PCI-E Required Items		23
Password-Authenticated Luna PCI-E		23
PED-Authenticated Luna PCI-E		24
Backup Device		27
Installing the Luna PCI-E Hardware		28
Installing the Luna PCI-E Card Into the Host Computer		28
Connecting a Local PED		30
Connecting a Remote PED		30
CHAPTER 3	Luna G5 Hardware Installation	32
Luna G5 Required Items		33
Password-Authenticated Luna G5		33
PED-Authenticated Luna G5		34
Additional Optional Items		36
Installing the Battery in the Luna G5 or Backup HSM		37
Installing the Luna G5 Hardware		39
CHAPTER 4	Luna Remote PED Installation and Configuration	44
Installing and Configuring a Luna Remote PED		45
Required Items		45
Remote PED Setup		47
CHAPTER 5	Luna Client Software Installation	53

AIX Luna Client Installation	54
Prerequisites	54
Installing the Client Software	55
Uninstalling the Luna Client Software	57
Java Component Installation	57
Interrupting the Installation	59
After Installation	59
HP-UX Luna Client Installation	60
Prerequisites	60
Installing the Luna Client Software	61
Uninstalling the Luna Client Software	63
Java Component Installation	63
Interrupting the Installation	64
After Installation	65
Linux Luna Client Installation	66
Prerequisites	66
Installing the Client Software	67
Uninstalling the Luna HSM Client Software	70
Java	70
Removing components	71
[Ctrl] [C] - If you interrupt the installation	71
Scripted or Unattended Installation	72
SUSE Linux on IBM PPC	73
32-bit Client on 64-bit RedHat 6	73
After Installation	75
Solaris Luna Client Installation	76
Prerequisites	76
Installing the Client Software	77
Uninstalling the Luna HSM Client Software	79
Java	79
Removing components	80
[Ctrl] [C] - If you interrupt the installation	80
After Installation	80
Windows Luna Client Installation	81
Required Client Software	81
Installing the Luna Client Software	81
Using msixexec for scripted or unattended installation of the Luna Client	85
Java	86
CSP and KSP	87
Using 32-bit Applications With the Luna Client	88
Uninstalling, Modifying, or Repairing the Luna Client Software	90
After Installation	90
Troubleshooting	90
Windows 2012 Luna Client Supplemental Configuration	94
Scripted / Unattended Installation on Windows	97
Installing the Luna Client For All Luna Products	97
Installing the Luna Client For Luna SA	97
Installing the Luna Client for Luna PCI-E	98
Installing the Luna Client For Luna G5	98

Installing the Luna Client for Luna Remote Backup HSM	99
Installing the Luna Client for Remote PED	99

About the Installation Guide

This document describes how to install the Luna HSM hardware and the Luna Client software. Refer to the following chapters to install the hardware and software components applicable to you:

Luna HSM hardware installation

- "Luna SA Hardware Installation" on page 11
- "Luna PCI-E Hardware Installation" on page 22
- "Luna G5 Hardware Installation" on page 32

Luna Remote PED installation and configuration

- "Luna Remote PED Installation and Configuration" on page 44

Luna Client software installation

- "Luna Client Software Installation" on page 53

Document information

This preface also includes the following information about this document:

- "Customer Release Notes" on page 7
- "Audience" on page 7
- "Document Conventions" on page 8
- "Support Contacts" on page 9

For information regarding the document status and revision history, see "Document Information" on page 2

Customer Release Notes

The customer release notes (CRN) provide important information about this release that is not included in the customer documentation. It is strongly recommended that you read the CRN to fully understand the capabilities, limitations, and known issues for this release. You can view or download the latest version of the CRN for this release at the following location:

- http://www.securedbysafenet.com/releasenotes/luna/crn_luna_hsm_6-0.pdf

Audience

This document is intended for personnel responsible for maintaining your organization's security infrastructure. This includes Luna HSM users and security officers, key manager administrators, and network administrators.

All products manufactured and distributed by SafeNet, Inc. are designed to be installed, operated, and maintained by personnel who have the knowledge, training, and qualifications required to safely perform the tasks assigned to them.

The information, processes, and procedures contained in this document are intended for use by trained and qualified personnel only.

It is assumed that the users of this document are proficient with security concepts.

Document Conventions

This document uses standard conventions for describing the user interface and for alerting you to important information.

Notes

Notes are used to alert you to important or helpful information. They use the following format:



Note: Take note. Contains important or helpful information.

Cautions

Cautions are used to alert you to important information that may help prevent unexpected results or data loss. They use the following format:



CAUTION: Exercise caution. Contains important information that may help prevent unexpected results or data loss.

Warnings

Warnings are used to alert you to the potential for catastrophic data loss or personal injury. They use the following format:



WARNING! Be extremely careful and obey all safety and security measures. In this situation you might do something that could result in catastrophic data loss or personal injury.

Command Syntax and Typeface Conventions

Format	Convention
bold	<p>The bold attribute is used to indicate the following:</p> <ul style="list-style-type: none"> • Command-line commands and options (Type <code>dir /p</code>.) • Button names (Click Save As.) • Check box and radio button names (Select the Print Duplex check box.) • Dialog box titles (On the Protect Document dialog box, click Yes.) • Field names (User Name: Enter the name of the user.) • Menu names (On the File menu, click Save.) (Click Menu > Go To > Folders.) • User input (In the Date box, type April 1.)

Format	Convention
<i>italics</i>	In type, the italic attribute is used for emphasis or to indicate a related document. (See the <i>Installation Guide</i> for more information.)
<variable>	In command descriptions, angle brackets represent variables. You must substitute a value for command line arguments that are enclosed in angle brackets.
[optional] [<optional>]	Represent optional keywords or <variables> in a command line description. Optionally enter the keyword or <variable> that is enclosed in square brackets, if it is necessary or desirable to complete the task.
{ a b c } {<a> <c>}	Represent required alternate keywords or <variables> in a command line description. You must choose one command line argument enclosed within the braces. Choices are separated by vertical (OR) bars.
[a b c] [<a> <c>]	Represent optional alternate keywords or variables in a command line description. Choose one command line argument enclosed within the braces, if desired. Choices are separated by vertical (OR) bars.

Support Contacts

Contact method	Contact
Address	SafeNet, Inc. 4690 Millennium Drive Belcamp, Maryland 21017 USA

Contact method	Contact	
Phone	Global	+1 410-931-7520
	Australia	1800.020.183
	China	(86) 10 8851 9191
	France	0825 341000
	Germany	01803 7246269
	India	000.800.100.4290
	Netherlands	0800.022.2996
	New Zealand	0800.440.359
	Portugal	800.1302.029
	Singapore	800.863.499
	Spain	900.938.717
	Sweden	020.791.028
	Switzerland	0800.564.849
	United Kingdom	0800.056.3158
United States	(800) 545-6608	
Web	www.safenet-inc.com	
Support and Downloads	www.safenet-inc.com/support Provides access to the SafeNet Knowledge Base and quick downloads for various products.	
Technical Support Customer Portal	https://serviceportal.safenet-inc.com Existing customers with a Technical Support Customer Portal account can log in to manage incidents, get the latest software upgrades, and access the SafeNet Knowledge Base.	



Luna SA Hardware Installation

This chapter describes how to install and connect a Luna SA HSM. To ensure a successful installation, perform the following tasks in the order indicated:

1. Ensure that you have all of the required components, as listed in "Luna SA Required Items" on page 12
2. Install and connect the hardware, as described in "Installing the Luna SA Hardware" on page 18

Luna SA Required Items

Follow this checklist to verify that you have all of items required for the installation.

Qty	Item
1	 <p>Luna SA HSM Appliance</p>
2	 <p>Power Supply Cord (one for each power supply; style to suit country for which you ordered)</p>
1	 <p>Null-Modem Serial Cable</p>

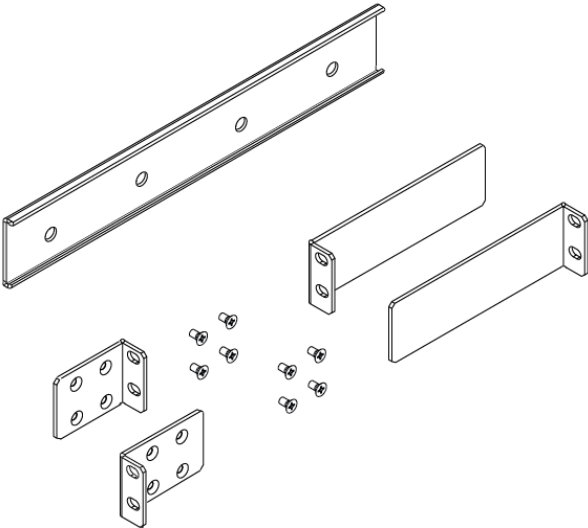
Qty	Item
1	 <p data-bbox="245 516 630 548">USB 2.0 to RS232 Serial Adapter</p>
1	 <p data-bbox="245 1184 1187 1318">Set of: - 2 front Mounting Brackets with Screws, - 2 Side Bracket Guides, and - 2 Sliding Rear Brackets (fit into the guides for rear support adjustable positioning).</p>

Qty	Item
1	 <p data-bbox="251 861 503 892">Client / SDK Software</p>



SafeNet Luna PED?

Additionally, if your Luna SA is the PED-authenticated version, then you might also have ordered the following items (next page).

Note that you can use Luna PEDs and PED Keys that you already own and use with other HSMs, if they have firmware 2.4.0 or later – PEDs of the same type are interchangeable, and PED Keys can be used with multiple HSMs if that is appropriate in your context. You should purchase the number you need for your own convenient operation, and for backup/standby units as your security policies might require.

If you intend to use Remote PED functions, you will need a Luna PED 2 Remote version.

The standard Luna PED 2 is capable of local operation only.

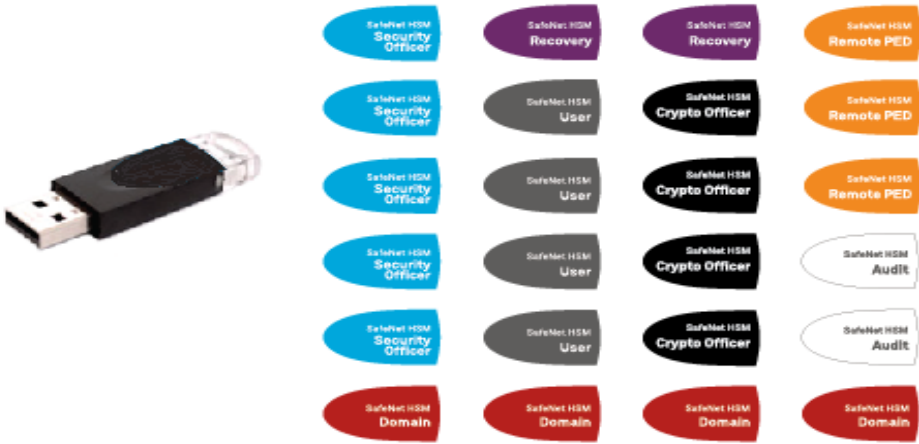
Qty	Item
1	 <p>SafeNet Luna PED2 (*)</p>
1	 <p>Cable, Data, 9-pin, Micro-D to Micro-D connectors (for local PED operation)</p>
1	

Qty	Item
	Set of iKey PED Keys and peel-and-stick labels

(* Standard PED 2 is shown. To use Luna SA with Remote PED function requires a Remote Capable PED – the standard PED does not have the Remote capability. They appear identical except for the availability of the “Remote” menu when powered on.)

Additional Options?

[Optionally]

You can back up your selected Luna SA HSM partition contents (root keys, certificates, other items) to a Luna Remote Backup HSM.

Qty	Item
1	 <p>Luna Backup HSM(*)</p>

(* The SafeNet Luna Backup HSM is a backup-storage option, suitable for off-site storage, and for backing up multiple HSM partitions. Its contents are automatically secured at the same level of authentication security (Password versus PED) as the HSM it is backing up. The Luna Backup HSM can be connected directly [locally] to an HSM, or it can be connected to a computer to backup remotely located HSMs, in conjunction with Remote PED.)

[Optionally]

You can use your Luna SA appliance to expand the functionality and reach of applications that you might previously have conducted with SafeNet PCMCIA tokens (Luna PCM and Luna PCM CA4), such as Registration Authority for SmartCard issuance, or Key Escrow for managed PKI implementations, or root-key management in the production of encrypted removable storage devices, among other possibilities. This function makes use of the Luna G5 HSM (very similar in appearance to the Backup HSM).

Qty	Item
1	 <p data-bbox="245 590 513 625">Luna G5 HSM (for PKI)</p>

The authentication method for external HSMs must match the authentication method for any appliance HSM with which they are used.

Installing the Luna SA Hardware

This section provides basic Luna SA hardware installation instructions (mounting in a rack, connecting cables, etc.). The Luna SA appliance comes with front brackets and side-rails and sliders for the rear brackets, packed separately in the carton.

Installation Notes

1. Any computer that is to act as a client to the Luna SA appliance must have the Client software installed. Windows users should log in to your computer as a user with Administrator privileges.
2. A computer that is to be used only for administering the Luna SA does not need the Client software – only an SSH client such as the PuTTY program that we have provided for Windows, or the SSH utilities that come standard with most Linux and UNIX platforms.
3. A computer that is to be used for Remote PED workstation operation against a Luna SA must have the PEDServer software and PED 2 USB driver installed. Applies to select Windows platforms only.
4. All three tasks (Client, administration, and Remote PED) can be performed on a single computer, but in normal practice they are often separate tasks for separate computers.
5. See the Remote PED section if you will be using Remote PED.

Installing the Luna SA Hardware

You can optionally install the brackets if they suit your equipment rack. The front brackets can be installed with their tabs forward (for flush-mount of the appliance) or reversed, to allow the front of the appliance to stand out from the rack. The rear brackets install in either direction – as appropriate for your rack post spacing – with the brackets simply sliding into the rails on each side of the appliance.

The supplied brackets are designed and intended for 4-point support of the appliance, in racks with rear-post depth up to 22 inches.



CAUTION: Do not attempt to mount the appliance using only the front brackets – damage can occur.



Note: The standard Luna PED 2 is capable of local operation only.

To install the Luna SA hardware

1. Install and adjust rails and brackets to suit your equipment rack.

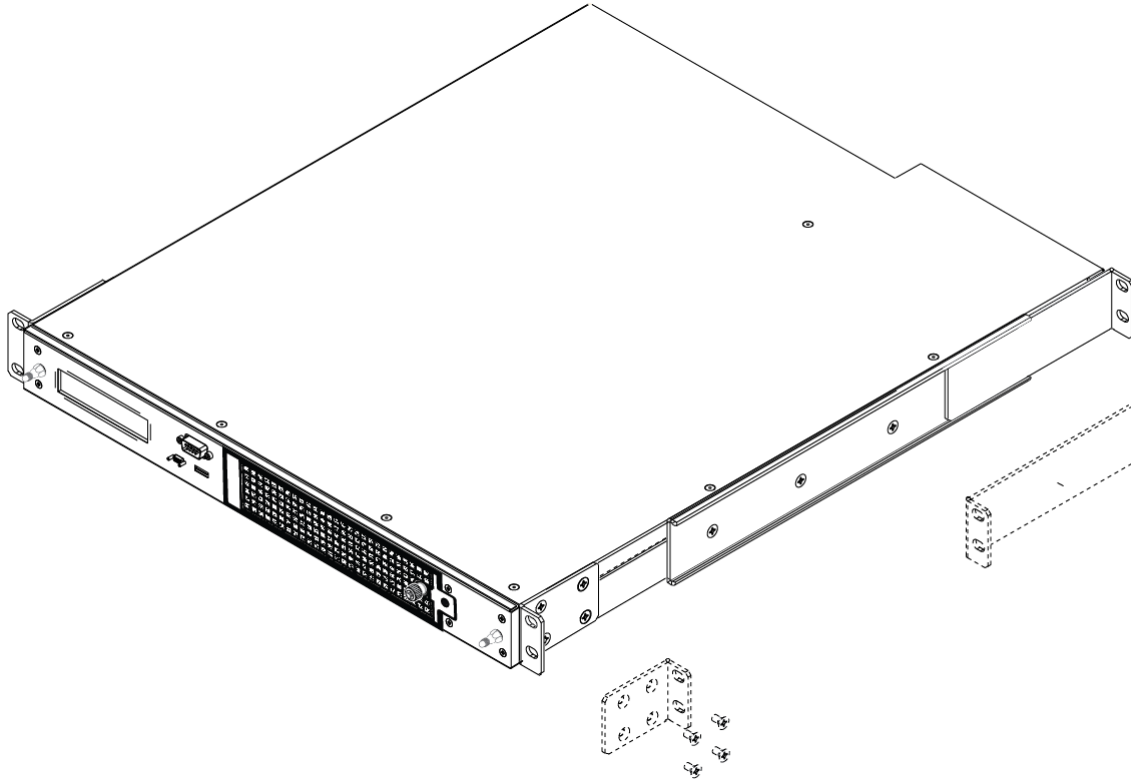

2. Mount the appliance in your equipment rack. Alternatively, ignore the rails and mounting tabs, and rest the Luna SA appliance on a mounting tray or shelf suitable for your specific style and brand of equipment rack.



CAUTION: Support the weight of the appliance until all four brackets are secured.

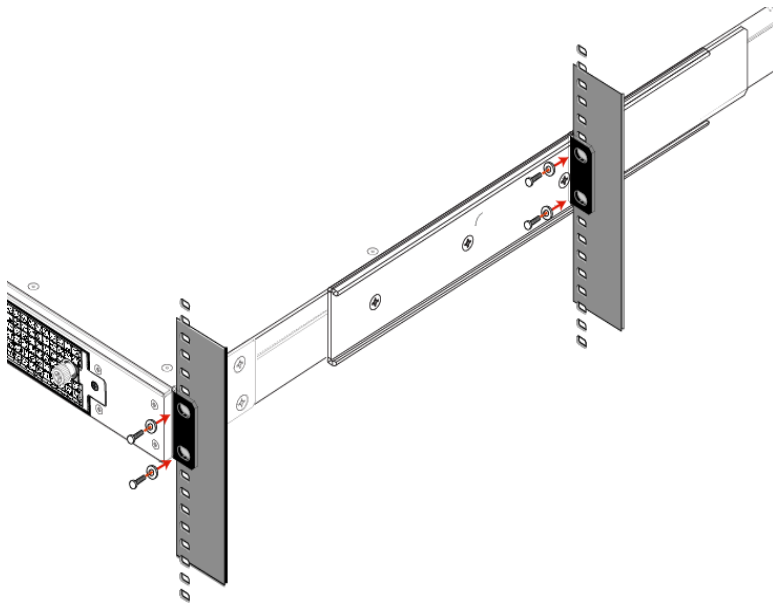

3. Insert the power (a) and network (b) cables at the rear panel.

For proper redundancy and best reliability, the power cables should connect to two completely independent power sources.

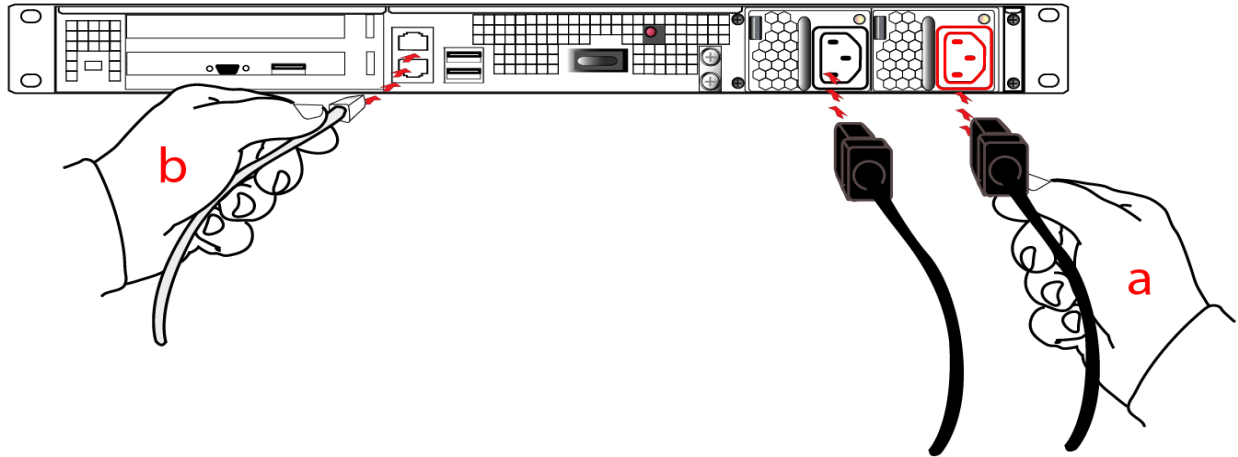

4. Connect the PED at the front panel, using the provided local PED cable – applies only for PED-authenticated HSM, otherwise skip to the next step.



5. Press and release the Start/Stop switch, on the rear panel.

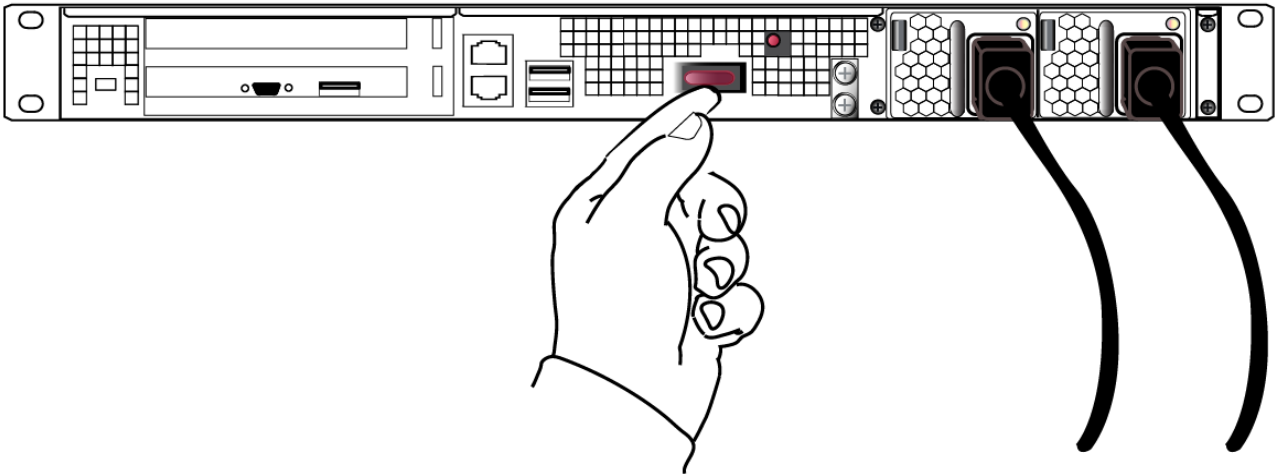

6. Connect a terminal to the serial connector on the front panel.

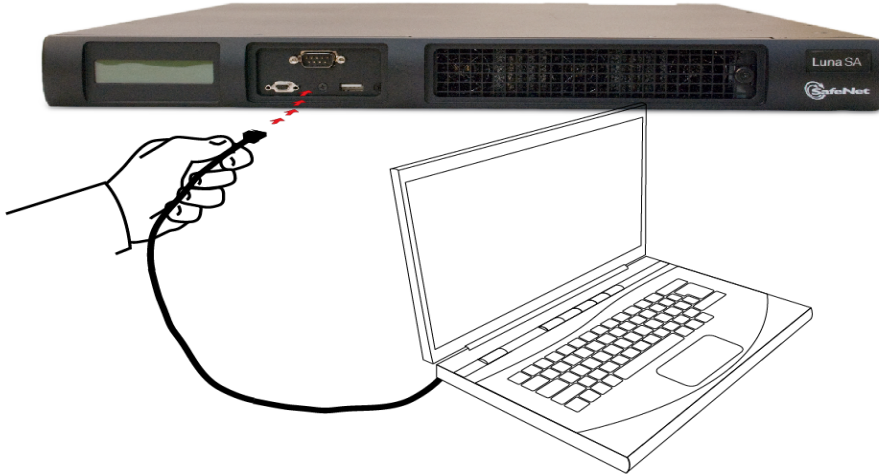

7. If you have already installed Luna Client software, go to the Configuration Guide, to configure your Luna HSM and peripheral devices, if appropriate.

Luna PCI-E Hardware Installation

This chapter describes how to install and connect a Luna PCI-E HSM. To ensure a successful installation, perform the following tasks in the order indicated:

1. Ensure that you have all of the required components, as listed in "Luna PCI-E Required Items" on page 23
2. Install and connect the hardware, as described in "Luna PCI-E Hardware Installation" on page 1

Will Luna PCI-E work with host computer/server XYZ ?

In the majority of modern host computers/servers with compliant PCI express slots, Luna HSM just works.

We test the Luna HSM in a variety of representative computer systems / servers from major manufacturers. However, we cannot possibly test with all computers that are available on the market, or that were sold in recent years, or that come to market after we release the product. When we learn of a compatibility problem with a current, important brand and model computer, we work with the manufacturer to identify and resolve the issue, if possible.

If we test - or if customers report - that the Luna HSM does not work with a particular brand, model, and configuration of host system, we make that information available in Release Notes or via our Technical Support organization, so that you can make the necessary decisions without wasting time and effort.

If we learn that a particular make and model of host computer is partially able to support the Luna HSM, we publicize that information, and we hope that you will tell us if you encounter such a situation that we have not already seen.

When installing the Luna HSM into a new server/host computer, always try more than one PCI express slot if you encounter any issues. It often happens that, due to quirks of motherboard design, or of the associated BIOS, some slots will work properly with Luna HSMs while others do not. Almost always, if a particular PCI express physical slot is intended for use with video cards, or has been specially designated by the host for a particular type of hardware, then you can expect trouble with that slot. It is very possible that simply moving the Luna HSM card to another empty PCI express slot or swapping with another installed adapter card will get your Luna HSM working in the chosen host computer/server.

Contact SafeNet Technical Support if you encounter problems, but expect some of their initial trouble-shooting questions to center around the use of alternate physical slots for installation of your Luna HSM.

Luna PCI-E Required Items

This section provides a list of the components you should have received with your Luna PCI-E order. The list of items you should have received depends on whether you ordered a password-authenticated Luna PCI-E or a PED-authenticated Luna PCI-E, and whether you order included a backup device, as described in the following sections:

Password-Authenticated Luna PCI-E

The following are the standard items that you should have received as your basic order for a password-authenticated Luna PCI-E:

Luna PCI-E HSM

Your order should include one Luna PCI-E 7000 or Luna PCI-E 1700 HSM. Both HSM models are physically identical.



Anti-Static Wrist Strap

Your order should include one anti-static wrist strap.



Software and Documentation

Your order should include a DVD case containing a Software DVD and a Documentation DVD.

PED-Authenticated Luna PCI-E

For local-only operation, where you work at the same computer that contains your Luna PCI-E HSM, you require at least a single, local-only Luna PED2. The standard Luna PED 2 is capable of local operation only.

If you intend to use Remote PED functions, you will need a Luna PED 2 (capable of remote or local PED operation).

If you intend to backup your Luna PCI-E HSM to a Backup HSM, then you require a Luna PED2 to connect to that Backup HSM.

If you intend to combine remote operation and backup, then you should have at least one remote-capable Luna PED2 (for remote connection to the Luna PCI-E HSM). For convenience you might prefer to have a second PED (which can be local-only for the Backup HSM). It is possible to use a single Remote-capable Luna PED2 for both connections, and to simply change modes (local or remote mode) as needed.

The following are the items that you receive when you purchase a standard Luna PED2 (local-only capable).

Note that you can use SafeNet PEDs and PED Keys that you already own and use with other HSMs – PEDs of the same type and version (v2.3.0 and later) are interchangeable, and PED Keys can be used with multiple HSMs if that is appropriate in your context (the only exception is the SRK, which is specific to a single Luna PCI-E HSM). You should purchase the number you need for your own convenient operation, and for backup/standby units as your security policies might require.

Luna PED

Your order should include a PED II device. To use Luna PCI-E with Remote PED function requires a Remote Capable PED – the standard PED does not have the Remote capability. They appear almost identical except for the words “Remote Capable” on the back, and the availability of the “Remote” menu when powered on.



Luna Local PED cable

Your order should include a 9-pin, Micro-D to Micro-D cable for local PED operation.



Luna Remote PED cable (Remote PED only)

If you ordered a Luna remote PED, your order should include a Type A to Mini B USB cable for remote PED operation.



Luna Remote PED Power Supply Kit (Remote PED only)

If you ordered a Luna remote PED, your order should include a Luna remote PED power supply kit. The power supply is auto-sensing and includes replaceable mains plug modules for international use.



PED Keys and Labels

Your order should include a set of iKey PED Keys and peel-and-stick labels.

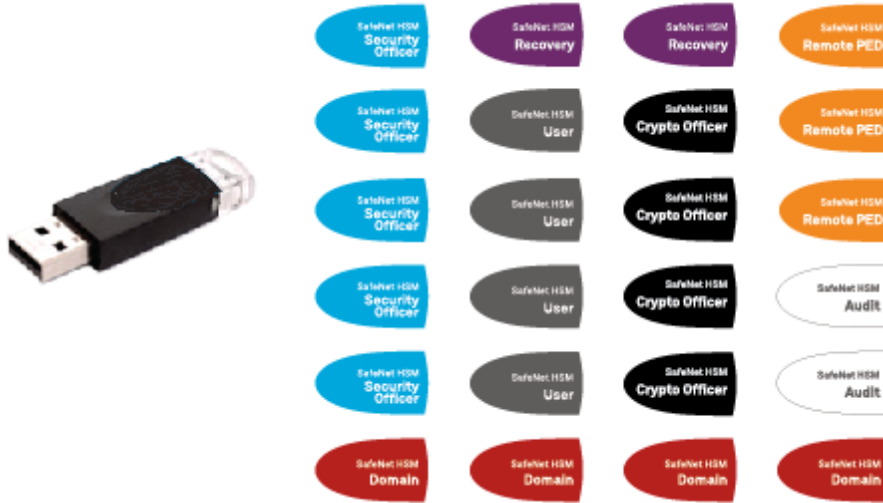

Backup Device

You can back up your selected Luna PCI-E HSM partition contents (root keys, certificates, other items) to a Luna Remote Backup HSM. The SafeNet Luna Remote Backup HSM is a backup-storage option, suitable for off-site storage, and for backing up multiple HSM partitions. The Backup HSM can backup contents of Password authenticated or of PED authenticated HSMs. It must be initialized as one or the other type before the backup operation starts.

The Luna Remote Backup HSM can be connected directly to an HSM, or it can be connected to a separate computer to backup remotely located HSMs, in conjunction with Remote PED.

The authentication method for external HSMs must match the authentication method for any internally installed HSM with which they are used (password or PED).

Luna Remote Backup HSM

Your order may include a Luna Remote Backup HSM.



Installing the Luna PCI-E Hardware

This section describes how to perform the following tasks:

- install the Luna PCI-E card into the host computer. See "Installing the Luna PCI-E Card Into the Host Computer" on page 28.
- connect a local PED, if necessary. See "Connecting a Local PED" on page 30
- connect a remote PED, if necessary. See "Connecting a Remote PED" on page 30

Installing the Luna PCI-E Card Into the Host Computer

You install the Luna PCI-E card into an open PCIe slot on the host computer.

To install the Luna PCI-E hardware

1. Open your computer, and remove the slot-cover bracket from an available PCIe slot. If the bracket is secured by a screw, retain that screw.
2. Use the provided anti-static wrist-strap to ground yourself to an exposed metal part of the computer chassis.



3. Remove the Luna PCI-E 7000 or Luna PCI-E 1700 from its anti-static packaging and prepare to insert the card into your computer.

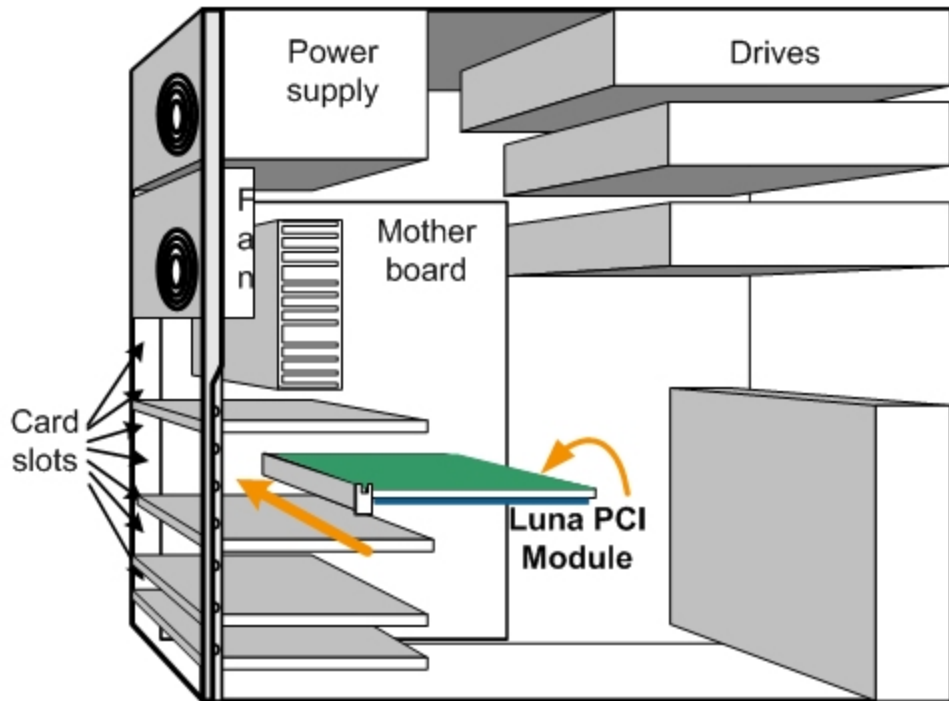

- Align the Luna PCI-E card with the vacant slot. You might need to introduce the tip of the card-hold-down bracket first (the silver-metal part along the back edge of the card), in order to properly align the card with the connector. You can use a PCIe X4 or larger slot, as long as it is wired for at least four PCI express channels, and not reserved for a dedicated function. For example, we do not recommend that you use your Luna PCI-E card in a designated PCI-express video slot - different models of computer and their BIOS firmware can differ in how faithfully they support the PCIe standard.

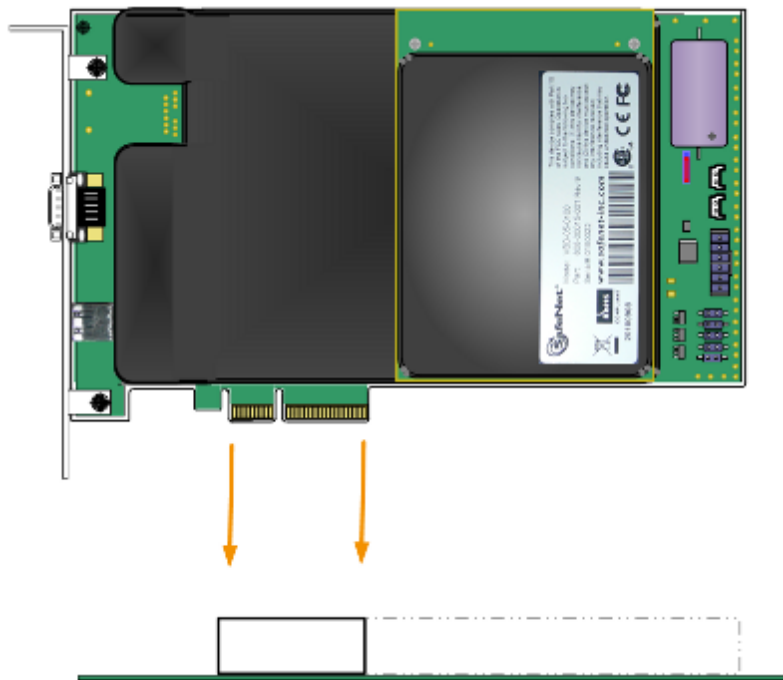

- Insert the Luna PCI-E card, gently but firmly, into the connector. It should go straight in – angling the card might

cause it to bind. The card is properly seated when no portion of the gold-colored contacts of the card protrudes above the connector socket.

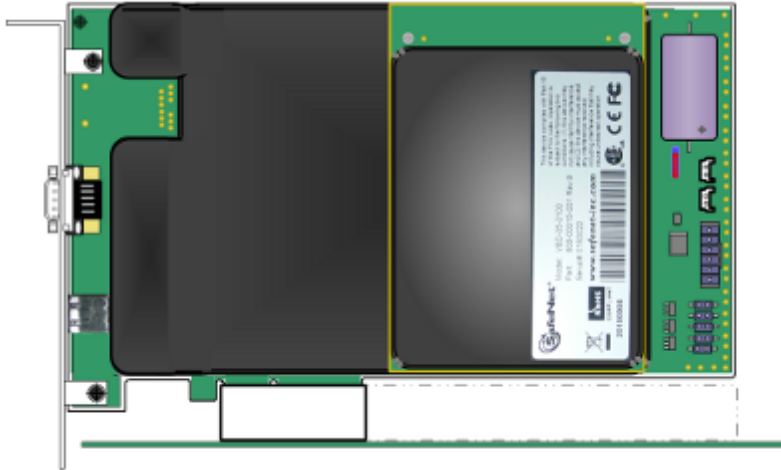

6. Secure the card-hold-down bracket with a screw.
7. Close the computer.

Connecting a Local PED

The local Luna PED (or a Luna PED Remote used locally) connects directly to the 9-pin Micro-D connector on the Luna PCI-E card.

To connect a local PED to the Luna PCI-E HSM

1. Use the Luna PED local cable (mini-D-shell 9-pin connectors at both ends) to connect the Luna PED to the Luna PCI-E card.



Connecting a Remote PED

The Remote-Capable PED can be used either locally, connected directly to a SafeNet HSM (exactly as for the standard PED), or remotely when connected to a suitable workstation and to the electrical main power supply. The normal local use of a PED with Remote PED capability is to use it in local mode to prepare an HSM (imprint an RPK – the orange key with a Remote PED Vector) before shipping it to its remote location. Then you would switch to Remote PED mode.

To prepare an HSM for Remote PED operation you need to connect it locally and imprint the HSM with a Remote PED Key (orange). Once the HSM can be reached via remote desktop connection, and the HSM is associated with an orange PED Key, all further configuration and administration can be performed remotely.

To connect a remote PED to the Luna PCI-E HSM

1. Use the Luna PED local cable to connect the Luna PED to the Luna PCI-E card. This step is required to imprint the HSM with a Remote PED Vector (RPV) using the orange PED key (RPK). This should be the only time you need to connect a PED locally to the HSM. Once the orange PED Key is imprinted with the same RPV as the HSM, all future PED operations can be performed remotely.



2. Follow the instructions in the *Administration Guide* to configure the remote PED. Note that you must install at least the Remote PED optional component of the Luna Client software before you can configure the remote PED. See "[Luna Client Software Installation](#)" on page 53.

Luna G5 Hardware Installation

This chapter describes how to install and connect a Luna G5 HSM. To ensure a successful installation, perform the following tasks in the order indicated:

1. Ensure that you have all of the required components, as listed in "Luna G5 Required Items" on page 33
2. Install the included removable battery, as described in "Installing the Battery in the Luna G5 or Backup HSM" on page 37. The Luna G5 requires the battery to operate.
3. Install and connect the hardware, as described in "Installing the Luna G5 Hardware" on page 39

Luna G5 Required Items

This section provides a list of the components you should have received with your Luna G5 order. The list of items you should have received depends on whether you ordered a password-authenticated Luna G5 or a PED-authenticated Luna G5, as described in the following sections:

Password-Authenticated Luna G5

The following are the standard items that you should have received as your basic order for a password-authenticated Luna G5:

Luna G5 HSM

Your order should include one Luna G5 HSM.



Power Cord

Your order should include one power supply cord for the Luna G5 HSM. The actual cord received depends on the country for which you ordered the Luna G5 HSM.



USB cable (USB A to USB mini B)

Your order should include one USB A to 5-pin (Mini-B) cable.



Software and Documentation

Your order should include a DVD case containing a Software DVD and a Documentation DVD.

PED-Authenticated Luna G5

Depending on your ordering options, the Luna G5 ships either in secure transport mode or with secure transport mode enabled, but turned off:

- If your Luna G5 was shipped in secure transport mode, you require the SRK PED Key (purple label) that was shipped separately from your Luna G5 to unlock your Luna G5. Note that each SRK PED key is specific to a certain Luna G5.
- If your Luna G5 was shipped with secure transport mode enabled, but turned off, no purple key is required initially.

Note that you can use SafeNet PEDs and PED Keys that you already own and use with other HSMs – PEDs of the same type and version (v2.3.0 and later) are interchangeable, and PED Keys can be used with multiple HSMs if that is appropriate in your context (the only exception is the SRK, which is specific to a single Luna G5). You should purchase the number you need for your own convenient operation, and for backup/standby units as your security policies might require.

If your Luna G5 is the PED-authenticated version, then you might also have ordered the items listed below.

Luna PED

Your order should include a PED II device.



Luna PED local cable

Your order should include a 9-pin, Micro-D to Micro-D cable for local PED operation.



PED Keys and Labels

Your order should include a set of iKey PED Keys and peel-and-stick labels.

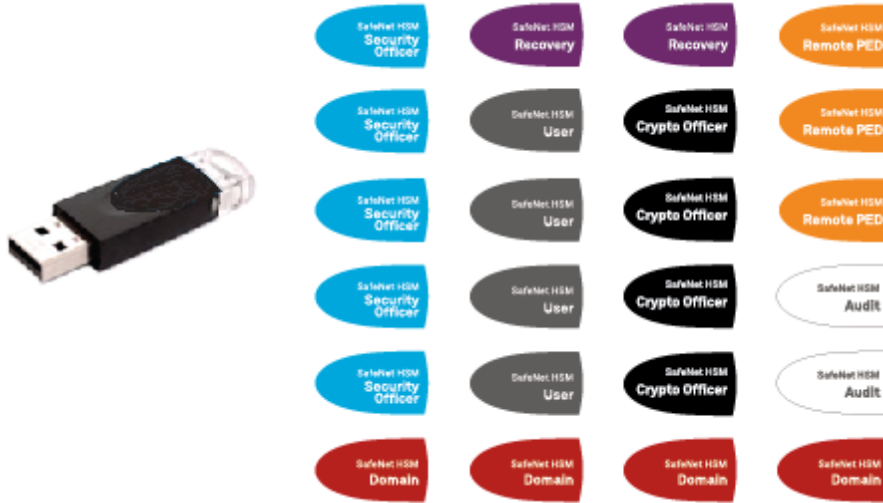

Additional Optional Items

Your order may also include the following optional item.

Luna G5 Rack-Mount Shelf

The SafeNet Luna G5 rack-mount shelf (available by separate order) fits a standard 19-inch equipment rack, allowing you to install up to two Luna G5 units side-by-side in server-room racks. For office use, without rack mounting, Luna G5 units can be placed on a desktop and are stackable.



Installing the Battery in the Luna G5 or Backup HSM

The battery is shipped with the Luna G5 device, but is not installed. You must install the battery before beginning to configure and use the Luna G5 device.

To install the battery in the Luna G5 or Luna Backup HSM

1. Remove the front faceplate. The faceplate is held in place by two spring clips. Grasp the faceplate firmly and pull to disengage the clips. Set the faceplate aside.



2. The battery compartment is to the right as you face the unit. The compartment cover is circular and has both raised dots and a recessed slot. Use finger-pressure against the dots, or use the edge of a coin in the slot, to twist the battery compartment cover $\frac{1}{4}$ turn in a counter-clockwise direction. The cover should fall out easily.



3. Remove the battery from its packaging and align it at the opening of the Luna G5 battery compartment. The battery should have a "+" sign near the end with the raised nub/bump. The flat end of the battery is the negative pole (-).
4. Insert the battery into the battery compartment, negative end first. The positive end (+) should protrude. The compartment is spring-loaded.



5. Use the battery compartment cover to push the battery into the compartment, against the spring tension. Maintaining the pressure, align the two tabs on the inside of the cover with the two recessed indentations at the top and bottom of the compartment opening. With a little jiggling and a few trial pushes, the tabs should settle into those recesses, allowing the cover to seat flush with the front of the Luna G5. Maintain the inward pressure and twist the cover $\frac{1}{4}$ turn clockwise to lock it in place. The battery is installed.
6. Replace the Luna G5 front-panel by aligning the clips with their respective posts and pushing until the clips grab the posts and the cover snaps in place.



7. The Luna G5 HSM or Luna Backup HSM is ready to connect to your host system.

Installing the Luna G5 Hardware

This section describes how to mount the Luna G5 and connect the cables and peripheral devices.

To install the Luna G5 hardware

1. If you are using the SafeNet Luna G5 rack-mount shelf, mount the shelf in a suitable equipment rack. Use fasteners appropriate to your brand of equipment rack. The shelf and the Luna G5 units are light-weight and therefore are adequately secured at the front only. Do not mount more than two Luna G5 devices, or any non-Luna G5 equipment, on the shelf.



2. Place your Luna G5 unit(s) on the shelf and push back until one of the index posts at the back edge of the shelf engages the index hole on the back panel of each Luna G5.



3. Insert the power (a) and USB (b) cables at the rear panel.

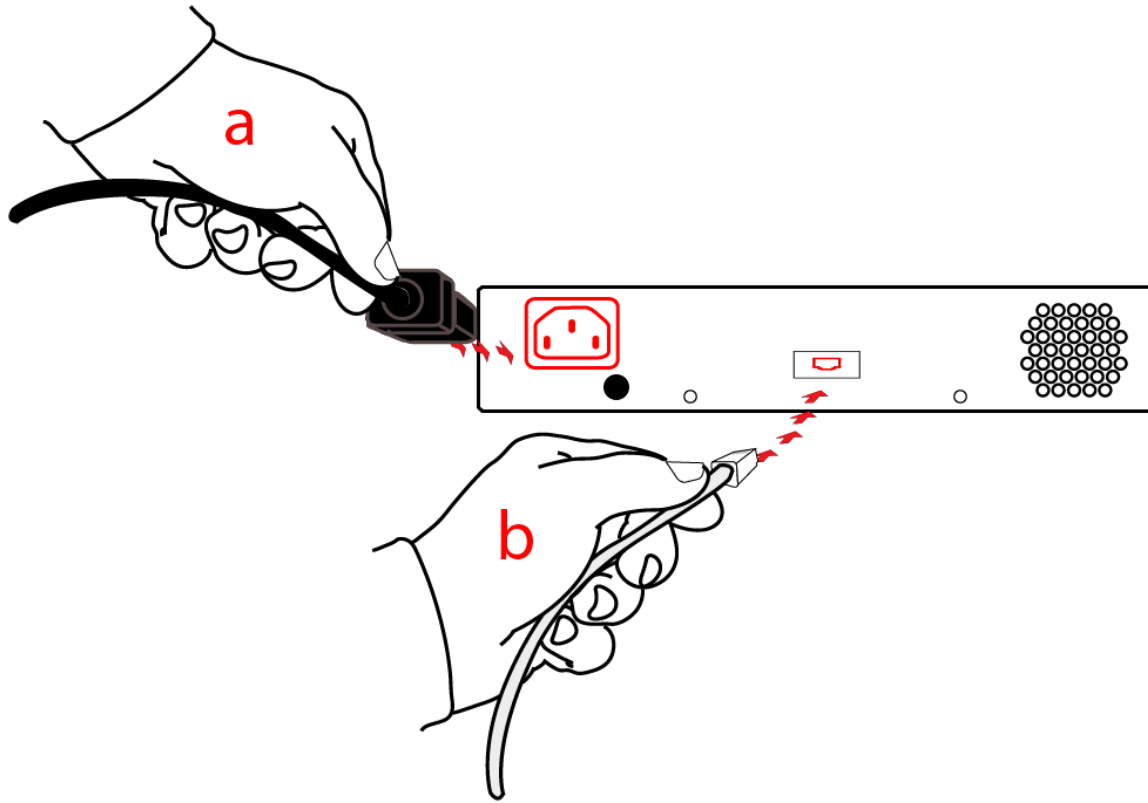

4. If you are installing a PED-authenticated Luna G5, connect the PED at the front panel, using the provided local PED cable.



5. Using the USB cable, connect the Luna G5 to a USB port on the Luna client computer.



CHAPTER 4

Luna Remote PED Installation and Configuration

This chapter describes how to install, connect, and configure a Luna Remote PED. It contains the following sections:

- "Installing and Configuring a Luna Remote PED" on page 45

Installing and Configuring a Luna Remote PED

The standard Luna PED is intended to connect directly to the HSM, and receives its power, as well as instructions and data via that connection. The Remote PED can act as a local PED, when needed, and connects as described above. When used in Remote PED mode, the Luna PED 2 connects to a computer via USB, and therefore requires some additional hardware.

Remote PED can be distinguished from local PED by:

- an orange label **PED Remote** to the right of the SafeNet logo 
- availability of menu item **[7] Remote PED** from the PED's main menu.

Required Items

The following items are included with your Remote PED. All are required for a successful installation.

Quantity	Item
1	Luna PED 2 (Remote PED Capable and with firmware 2.4.0-3 or greater) 
1	Luna PED Power Supply kit with replaceable mains plug modules for international use (required when the PED is operated in Remote PED mode)

Quantity	Item
	
1	<p>Cable, USB 2.0, Type A to Mini B connectors (for Remote PED operation).</p> 
1	<p>Cable, Data, 9-pin, Micro-D to Micro-D connectors (for local PED operation).</p> 
1	<p>Ten-pack of iKey 1000 PED Keys, and sheets of peel-and-stick labels</p>

Quantity	Item



Remote PED Setup

The Remote-Capable PED can be used either locally, connected directly to a SafeNet HSM (exactly as for the standard PED), or remotely when connected to a suitable workstation and to the electrical main power supply.

The normal local use of a PED with Remote PED capability is to use it in local mode to prepare an HSM. This is done by imprinting an RPV (remote PED vector) onto the HSM and also onto an RPK (the orange Remote PED Key) before shipping the HSM to its remote location. Then the PED can be switched to Remote PED mode, to serve any HSM that has an appropriate RPV.

To configure the remote PED

Step	Action
1	Local OPERATION [Ongoing] To use your HSM appliance and PED for local operation only, refer to the instructions in the Configuration Guide and the HSM Administration Guide.
2	Local OPERATION [Preparing for Remote Use] To prepare an HSM for Remote PED operation, it needs a minimum of preparation as described in this section, below.
3	[Preliminary] From the software media (DVD or downloaded, un-tarred archive file), install the LunaClient software, ensuring that Remote PED option is selected, onto the selected Windows computer that will act as the PED server to your remotely located SafeNet HSM, and let the Windows “Found New Hardware” dialog install it. The PedServer.exe and PedClient.exe applications are installed in the LunaClient folder along with any other Luna tools.
4	[Preliminary] Imprint the HSM with a Remote PED Key (orange); see below. Once the HSM is associated with an orange PED Key, all further configuration and administration can be



Step	Action
	performed remotely.
5	<p>To use the PED locally (for first orange PED Key imprint), connect the PED directly to the PED port of the HSM that you will later be using remotely.</p>  <p>OR</p>  <p>OR</p> 
6	On power-up, the PED defaults to local mode.

Step	Action
	 <p>Follow the instructions in the SafeNet HSM documentation to:</p> <ul style="list-style-type: none"> • [for Luna SA only] log in as “admin” to the appliance (SSH session or local serial connection) • [for Luna SA] issue the Luna shell command hsm ped vector init, or [for Luna PCI-E or Luna G5] issue the lunacm command ped vector init, inserting a blank (orange-labeled) PED Key into the PED, when prompted OR inserting an already-imprinted orange PED Key and select “re-use” at the PED prompt • bring the imprinted (orange) Remote PED Key to your workstation, along with a Remote-capable PED • the HSM can now be shipped to its remote locale <p>You can perform other maintenance at this time, if convenient, but only the foregoing steps were required to be done locally - all future configuration and administration can be performed remotely.</p>

To use the Remote PED

Once an HSM has been imprinted with a Remote PED Key (RPK) vector, you can begin administering remotely, while also authenticating remotely from any workstation that has PEDServer software and driver, a remote-capable PED, and an orange PED Key with the correct RPK (that you just imprinted in the previous steps).

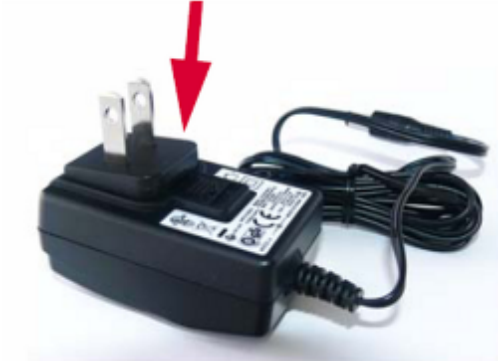
Step	Action
1	REMOTE OPERATION Perform the following steps to begin using your computer as a PED Server Workstation, connecting remotely to the distant HSM appliance.
2	[Prepare the PED Power Supply] On the PED power supply, slide the release catch as shown by the heavy arrow, and lift the pin protector (thinner arrow) from the power supply.

Step	Action
	 <p>The pin protector was used during shipment only.</p>
3	<p>Choose a plug style that is appropriate for your country and place it in the power supply, top end first, then snap the bottom end in the direction indicated by the arrow.</p> 
4	<p>For Remote PED operation:</p> <ul style="list-style-type: none"> connect the power supply to the AC mains, connect the DC power plug of the power supply to the DC power receptacle on the top of the PED, 

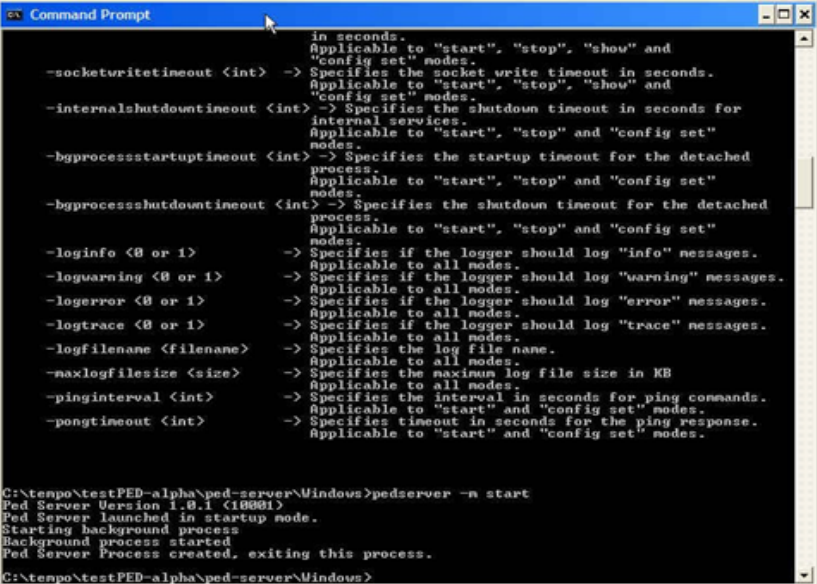
Step	Action
	<ul style="list-style-type: none"> connect the USB cable between the USB micro connector on the PED and a USB socket on your computer.
5	<p>At the workstation-connected PED:</p> <ul style="list-style-type: none"> press [<] on the PED keypad to exit Local mode,  <ul style="list-style-type: none"> press [7] to enter Remote PED mode.
6	<p>In a command-prompt window on the workstation start the PEDserver program in its listening mode c:\<yourRemotePED-dir>\pedserver -m start</p> 

Step	Action
7	Run the command <code>pedserver -m show</code> to verify that the PED is detected, and the system is ready for remote connection.
8	<p>Start the PED Client - the Remote PED enabling process on the HSM host(for example):</p> <pre>lunash:> hsm ped connect -ip 192.2.12.16 - port 1503</pre> <p>or</p> <pre>lunacm:> ped connect -ip 192.2.12.16 - port 1503</pre> <p>The Remote PED Client in the HSM appliance connects with the listening PEDserver (your workstation).</p>
9	<p>Perform an hsm login or role login -name SO (as appropriate. The PED prompts first for the Remote PED Key. Insert the imprinted Remote PED Key associated with the connecting HSM appliance, and press [Enter].</p>  <p>Then the PED prompts for the HSM SO's blue PED Key. Insert that and press [Enter]. A successful login confirms that the Remote PED connection is running properly.</p>
10	Begin using and administering the remotely located SafeNet HSM appliance via ssh session, and providing PED Key authentication via the workstation-connected Remote PED, whenever requested. Review the Luna SA Help for information about timeouts with respect to Remote PED.

Luna Client Software Installation

This chapter describes how to install the Luna Client software. After installing the hardware, you need to install the Luna Client software, as follows, before you can begin configuring your Luna HSM(s):

- For Luna SA, install the Luna Client on any computer that must connect to the appliance as a client.
- For Luna PCI-E, install the Luna Client on the workstation into which the Luna PCI-E HSM is installed.
- For Luna G5, install the Luna Client on the workstation to which the Luna G5 HSM is connected.
- Install the Luna Client on any computer that is to have a Luna Remote PED connected.

Choose the instructions for your operating system:

- For AIX, see "AIX Luna Client Installation" on page 54.
- For HP-UX, see "HP-UX Luna Client Installation" on page 60.
- For Linux, see "Linux Luna Client Installation " on page 66.
- For Solaris, see "Solaris Luna Client Installation" on page 76
- For Windows, see "Windows Luna Client Installation" on page 81 The following supplemental topics also apply to Windows:
 - "Windows 2012 Luna Client Supplemental Configuration" on page 94
 - "Scripted / Unattended Installation on Windows" on page 97



Note: Not all operating systems are supported for each Luna HSM type. Refer to the Customer Release Notes (see "Customer Release Notes" on page 7) for the most current information on supported platforms.

AIX Luna Client Installation

These instructions assume that you have already acquired the Luna Client software, either on DVD or in the form of a downloaded .tar archive. Applicability to specific versions of AIX is summarized in the Customer Release Notes for the current release.



Note: Before installing a Luna system, you should confirm that the product you have received is in factory condition and has not been tampered with in transit. Refer to the Content Sheet included with your product shipment. If you have any questions about the condition of the product that you have received, please contact SafeNet Support.

Each computer that connects to the Luna HSM appliance as a Client must have the cryptoki library, the vtl client shell and other utilities and supporting files installed. Each computer that contains, or is connected to a Luna G5 or a Luna PCI-E HSM must have the cryptoki library and other utilities and supporting files installed.



Note: This example shows all the Luna Client products and components. Some items are not supported on all operating systems and therefore do not appear as you proceed through the installation script.

Do not install Luna client software on the same system as legacy Luna CA³, Luna CA4, Luna PCM, or Luna PCI software. The software is intended for modern/current Luna HSMs, Luna SA, Luna PCI-E, Luna G5, Luna (Remote) Backup HSM.

Prerequisites

Before starting the installation, ensure that you have a Random Number Generator (RNG) or Entropy Gathering Daemon (EGD) on your system in one of the following locations:

- /dev/egd-pool
- /etc/egd-pool
- /etc/entropy
- /var/run/egd-pool

RNG/EGD

Cryptographic algorithms, including those that assure the security of communication – such as in OpenSSL and other protocols – depend upon random numbers for the creation of strong keys and certificates. A readily available source of random data is the entropy that exists in complex computer processes. Utilities exist for every operating system, to gather bits of system entropy into a pool, which can then be used by other processes.

Windows and Linux have these installed by default. Other systems might or might not. See your system administrator.

You Need an Entropy Pool

In the case of Luna SA, the Luna Client administration tool (vtl) expects to find a source of randomness at **/dev/random**. If one is not found, **vtl** fails, because the link cannot be secured from the Client end.

If your system does have an entropy pool, but the random number generator (RNG) is not in the expected place, then you can create a symbolic link between the actual location and one of the following:

- /dev/random
- /dev/egd-pool
- /etc/egd-pool
- /etc/entropy
- /var/run/egd-pool

If your system does not have an entropy gathering daemon or random number generator, please direct your system administrator to install one, and point it to one of the named devices.

Packages Required to Build the Driver on G5, PCI-E, and Remote Backup HSM Clients

If you are installing the Luna PCI-E, or Luna G5, or Luna Remote Backup HSM clients, ensure that the following items are installed:

- Kernel headers for build
- rpm-build package
- C and C++ compilers
- make command

These items are required because the driver module is built on Linux before it is installed. If one of these items is missing, the driver build will fail and the module will not get installed.

Installing the Client Software

Check the Luna HSM Customer Release Notes for any installation-related issues or instructions before you begin the following software installation process.



CAUTION: You must be logged in as **root** when you run the installation script.

To install the Luna Client software on AIX

1. Log on to the client system, open a console or terminal window, and use **su** to gain administrative permissions for the installation.
2. If you have downloaded the Luna Client software as a .tar archive, skip to step 6.
3. Insert the DVD (mount it if you do not have automount).
4. Go to the DVD (/cdrom or whatever devicename your system uses) and the install directory:

32-bit OS	cd /cdrom/AIX/32
64-bit OS	cd /cdrom/AIX/64



Note: Not all platforms are supported with each release, so the available install options might not match the list above.

5. Skip to step 9.
6. If you downloaded the software, copy or move the .tar archive (which usually has a name like "Luna Client_6.x.y-nn.tar") to a suitable directory where you can untar the archive and launch the installation script.

7. Enter the following command to extract the contents from the archive:

```
tar xvf Luna Client<version>.tar
```

8. Change directory to the software version suitable for your system (for example, under the "aix" subdirectory, choose 32-bit or 64-bit according to your system requirement).

9. Install the client software as follows:

- To see the 'help', or a list of available installer options, type:

```
sh install.sh -? or ./sh install.sh --help
```

- To install all available products and optional components, type:

```
sh install.sh all
```

- To selectively install individual products and optional components, type the command without arguments:

```
sh install.sh
```

10. Type "y" if you agree to be bound by the license agreement:

```
[mylunaclient-1 32]$ sh install.sh
```

```
IMPORTANT: The terms and conditions of use outlined in the software
license agreement (Document #008-010005-001_053110) shipped with the product
("License") constitute a legal agreement between you and SafeNet Incorporated.
Please read the License contained in the packaging of this
product in its entirety before installing this product.
```

```
Do you agree to the License contained in the product packaging?
```

```
If you select 'yes' or 'y' you agree to be bound by all the terms
and conditions set out in the License.
```

```
If you select 'no' or 'n', this product will not be installed.
```

```
(y/n)
```

11. A list of installable Luna products appears (might be different, depending on your platform). Select as many as you require, by typing the number of each (in any order) and pressing Enter. As each item is selected, the list updates, with a "*" in front of any item that has been selected. This example shows item 1 has been selected.

```
Products
  Choose Luna Products to be installed
    *[1]: Luna SA
    [2]: Luna PCI-E
    [N|n]: Next
    [Q|q]: Quit
Enter selection: 2
```



Note: When the above was captured, AIX supported only Luna SA and Luna PCI-E among SafeNet HSM products. To install Luna G5 or the Luna [Remote] Backup HSM, you will need one of the other supported host platforms.

12. When selection is complete, type "N" or "n" for "Next", and press Enter. If you wish to make a change, simply type a number again and press Enter to de-select a single item.

13. The next list is called "Advanced" and includes additional items to install. Some items might be pre-selected to provide the optimum Luna HSM experience for the majority of customers, but you can change any selection in the list.

```
Products
Choose Luna Products to be installed
*[1]: Luna SA
  [2]: Luna PCI-E
  [N|n]: Next
  [Q|q]: Quit
Enter selection: n
```

If you wish to make a change, simply type a number again and press Enter to de-select a single item.

If the script detects an existing cryptoki library, it stops and suggests that you uninstall your previous Luna software before starting the Luna Client installation again.

14. The system installs all packages related to the products and any optional components that you selected. By default, the Client programs are installed in the **/usr/safenet/lunaclient** directory.

As a general rule, do not modify the `Chrystoki.conf/crystoki.ini` file, unless directed to do so by SafeNet Customer Support. If you do modify the file, never insert TAB characters - use individual space characters. Avoid modifying the PED timeout settings. These are now hardcoded in the appliance, but the numbers in the `Chrystoki.conf` file must match.

Uninstalling the Luna Client Software

You may need to uninstall the Luna Client software prior to upgrading to a new release, or if the software is no longer required. You must be logged in as root.

To uninstall the Luna HSM client software

1. Log in as root.
2. Go to the client installation directory:

```
cd /usr/safenet/lunaclient/bin
```

3. Run the uninstall script:

```
sh uninstall.sh
```

Java Component Installation

During the installation, the script provides the opportunity to install Luna Java components. If you select Java components, the Luna Java files are installed in the **/usr/safenet/lunaclient/jsp/** directory. In order to use Java, you must have separately installed Java (JDK or run-time environment from the vendor of your choice) onto your system.

Copy the Luna Java library and jar files from their default location under **/usr/safenet/lunaclient/jsp/lib** to the Java environment directory, for example **/usr/jre/lib/ext**. The exact directory might differ depending on where you obtained your Java system, the version, and any choices that you made while installing and configuring it.



CAUTION: Copy `libLunaAPI.so` to system lib (`/usr/lib`) in order to make either `java5` or `java6` work on AIX 6.1 64-bit client.

For additional Java-related information, see "Java Interfaces" on page 1 in the *SDK Reference Guide*.

JSP Static Registration

You would choose static registration of providers if you want all applications to default to our (SafeNet) provider.

Once your client has externally logged in using `salogin` (see) in the Reference section of this document) or your own HSM-aware utility, any application would be able to use Luna product without being designed to login to the HSM Partition.

Edit the `java.security` file located in the `\jre\lib\security` directory of your Java SDK/JRE 1.6.x or 1.7.x installation to read as follows:

```
security.provider.1=sun.security.provider.Sun
security.provider.2=com.sun.net.ssl.internal.ssl.Provider
security.provider.3=com.safenetinc.luna.provider.LunaProvider
security.provider.4=com.sun.rsa.jca.Provider
security.provider.5=com.sun.crypto.provider.SunJCE
security.provider.6=sun.security.jgss.SunProvider
```

You can set our provider in first position for efficiency if Luna HSM operations are your primary mode. However, if your application needs to perform operations not supported by the `LunaProvider` (secure random generation or random publickey verification, for example) then it would receive error messages from the HSM and would need to handle those gracefully before resorting to providers further down the list. We have found that having our provider in third position works well for most applications.

The modifications in the "java.security" file are global, and they might result in the breaking of another application that uses the default `KeyPairGenerator` without logging into the Luna SA first. This consideration might argue for using dynamic registration, instead.

JSP Dynamic Registration

For your situation, you may prefer to employ dynamic registration of Providers, in order to avoid possible negative impacts on other applications running on the same machine. As well, the use of dynamic registration allows you to keep installation as straightforward as possible for your customers.

Compatibility

We formally test Luna HSMs and our Java provider with SUN JDK for all platforms except AIX, and with IBM JDK for the AIX platform. We have not had problems with OpenJDK, although it has not been part of our formal test suite. The Luna JCE provider is compliant with the JCE specification, and should work with any JVM that implements the Java language specification.

Occasional problems have been encountered with respect to IBM JSSE.

GNU JDK shipped with most Linux systems has historically been incomplete and not suitable.

Remove components

To uninstall the JSP component or the SDK component, you must uninstall Luna Client completely (see "[Uninstalling the Luna Client Software](#)" on page 57), then re-run the installation script without selecting the unwanted component(s).

Interrupting the Installation

Do not interrupt the installation script in progress, and ensure that your host computer is served by an uninterruptible power supply (UPS). If you press [Ctrl] [C], or otherwise interrupt the installation (OS problem, power outage, other), some components will not be installed. It is not possible to resume an interrupted install process. The result of an interruption depends on where, in the process, the interruption occurred (what remained to install before the process was stopped).

As long as the cryptoki RPM package is installed, any subsequent installation attempt results in refusal with the message "A version of Luna Client is already installed."

If components are missing or are not working properly after an interrupted installation, or if you wish to install any additional components at a later date (following an interrupted installation, as described), you would need to uninstall everything first. If 'sh uninstall.sh' is unable to do it, then you must uninstall all packages manually.

Because interruption of the install.sh script is not recommended, and mitigation is possible, this is considered a low-likelihood corner case, fully addressed by these comments.

After Installation

When you have installed the software onto a Client, the next task is to configure the Luna HSM, as described in the *Configuration Guide*.

HP-UX Luna Client Installation

These instructions assume that you have already acquired the Luna Client software, either on CD/DVD or in the form of a downloaded .tar archive. Applicability to specific versions of HP-UX is summarized in the Customer Release Notes for the current release. See "Customer Release Notes" on page 7 for more information.



Note: Before installing a Luna system, you should confirm that the product you have received is in factory condition and has not been tampered with in transit. Refer to the Content Sheet included with your product shipment. If you have any questions about the condition of the product that you have received, please contact SafeNet Support.

Each computer that connects to the Luna HSM appliance as a Client must have the cryptoki library, the vtl client shell and other utilities and supporting files installed. Each computer that contains, or is connected to, a Luna G5 or a Luna PCI-E HSM must have the cryptoki library and other utilities and supporting files installed.



Note: This example shows all the Luna Client products and components. Some items are not supported on all operating systems and therefore do not appear as you proceed through the installation script.

Do not install Luna client software on the same system as legacy Luna CA³, Luna CA4, Luna PCM, or Luna PCI software. The software is intended for modern/current Luna HSMs, Luna SA, Luna PCI-E, Luna G5, Luna (Remote) Backup HSM.

Prerequisites

Before starting the installation, ensure that you have a Random Number Generator (RNG) or Entropy Gathering Daemon (EGD) on your system in one of the following locations:

- /dev/egd-pool
- /etc/egd-pool
- /etc/entropy
- /var/run/egd-pool

RNG/EGD

Cryptographic algorithms, including those that assure the security of communication – such as in OpenSSL and other protocols – depend upon random numbers for the creation of strong keys and certificates. A readily available source of random data is the entropy that exists in complex computer processes. Utilities exist for every operating system, to gather bits of system entropy into a pool, which can then be used by other processes.

Windows and Linux have these installed by default. Other systems might or might not. See your system administrator.

You Need an Entropy Pool

In the case of Luna SA, the Luna Client administration tool (vtl) expects to find a source of randomness at **/dev/random**. If one is not found, **vtl** fails, because the link cannot be secured from the Client end.

If your system does have an entropy pool, but the random number generator (RNG) is not in the expected place, then you can create a symbolic link between the actual location and one of the following:

- /dev/random
- /dev/egd-pool
- /etc/egd-pool
- /etc/entropy
- /var/run/egd-pool

If your system does not have an entropy gathering daemon or random number generator, please direct your system administrator to install one, and point it to one of the named devices.

Installing the Luna Client Software

Check the Luna HSM Customer Release Notes for any installation-related issues or instructions before you begin the following software installation process.



CAUTION: You must be logged in as **root** when you run the installation script.

To install the Luna Client software on HP-UX

1. Log on to the client system, open a console or terminal window, and use **su** to gain administrative permissions for the installation.
2. If you have downloaded the Luna Client software as a .tar archive, skip to step 6.
3. Insert the Luna Client software DVD (mount it if you do not have automount).
4. Go to the DVD (/cdrom or whatever device name your system uses) and the install directory for your architecture, for example:

32-bit OS	cd /cdrom/hpux/IA/32
64-bit OS	cd /cdrom/hpux/IA/64

5. Skip to step 9.
6. If you downloaded the software, copy or move the .tar archive (which usually has a name like "Luna Client_5.x.y-nn.tar") to a suitable directory where you can untar the archive and launch the installation script.
7. Enter the following command to extract the contents from the archive:

```
tar xvf Luna Client<version>.tar
```
8. Change directory to the software version suitable for your system (for example, under the "hpux" subdirectory, in the "x86" directory, choose 32-bit or 64-bit according to your system requirement).
9. Install the client software as follows:
 - To see the help, or a list of available installer options, type:

```
sh install.sh -? or sh install.sh --help
```
 - To install all available products and optional components, type:

```
sh install.sh all
```

- To selectively install individual products and optional components, type the command without arguments:

```
sh install.sh
```

10. Type **y** if you agree to be bound by the license agreement:

```
[mylunaclient-1 32]$ sh install.sh
```

```
IMPORTANT: The terms and conditions of use outlined in the software
license agreement (Document #008-010005-001_053110) shipped with the product
("License") constitute a legal agreement between you and SafeNet Incorporated.
Please read the License contained in the packaging of this
product in its entirety before installing this product.
```

```
Do you agree to the License contained in the product packaging?
```

```
If you select 'yes' or 'y' you agree to be bound by all the terms
and conditions set out in the License.
```

```
If you select 'no' or 'n', this product will not be installed.
```

```
(y/n)
```

11. A list of installable Luna products appears (might be different, depending on your platform). Select as many as you require, by typing the number of each (in any order) and pressing [Enter]. As each item is selected, the list updates, with a "*" in front of any item that has been selected. This example shows item 1 has been selected, and item 2 is about to be selected:

```
Products
Choose Luna Products to be installed
*[1]: Luna SA
  [2]: Luna PCI-E
  [N|n]: Next
  [Q|q]: Quit
Enter selection: 2
```



Note: When the above was captured, HP-UX supported only Luna SA and Luna PCI-E among SafeNet HSM products. To install Luna G5 or the Luna [Remote] Backup HSM, you will need one of the other supported host platforms.

12. When selection is complete, type "N" or "n" for "Next", and press Enter. If you wish to make a change, simply type a number again and press Enter to de-select a single item.
13. The next list is called **Advanced** and includes additional items to install. Some items might be pre-selected to provide the optimum Luna HSM experience for the majority of customers, but you can change any selection in the list.

```
Products
Choose Luna Components to be installed
  [1]: Luna Software Development Kit (SDK)
*[2]: Luna JSP (Java)
*[3]: Luna JProv (Java)
*[4]: Crypto Command Center Provisioning Client
*[5]: Luna SNMP subagent
  [B|b]: Back to Products Selection
  [I|i]: Install
  [Q|q]: Quit
Enter selection: n
```

When the Components list is adjusted to your satisfaction, press Enter.



Note: The installer includes the Luna SNMP Subagent as an option. After installation is complete, you will need to move the SafeNet MIB files to the appropriate directory for your SNMP application, and you will need to start the SafeNet subagent and configure for use with your agent. See the *Administration Guide* for more information.

If the script detects an existing cryptoki library, it stops and suggests that you uninstall your previous Luna software before starting the Luna Client installation again.

14. The system installs all packages related to the products and any optional components that you selected. By default, the Client programs are installed in the **/opt/safenet/lunaclient** directory.

As a general rule, do not modify the `Chrystoki.conf/crystoki.ini` file, unless directed to do so by SafeNet Customer Support. If you do modify the file, never insert TAB characters - use individual space characters. Avoid modifying the PED timeout settings. These are now hardcoded in the appliance, but the numbers in the `Chrystoki.conf` file must match.

Uninstalling the Luna Client Software

You may need to uninstall the Luna Client software prior to upgrading to a new release, or if the software is no longer required. You must be logged in as root.

To uninstall the Luna HSM client software

1. Log in as root.
2. Go to the client installation directory:
cd /opt/safenet/lunaclient/bin
3. Run the uninstall script:
sh uninstall.sh

Java Component Installation

During the installation, the script provides the opportunity to install Luna Java components. If you select Java components, the Luna Java files are installed in the **/opt/safenet/lunaclient/jsp/** directory. In order to use Java, you must have separately installed Java (JDK or run-time environment from the vendor of your choice) onto your system.

Copy the Luna Java library and jar files from their default location under **/opt/safenet/lunaclient/jsp/lib** to the Java environment directory, for example **/opt/jre/lib/ext**. The exact directory might differ depending on where you obtained your Java system, the version, and any choices that you made while installing and configuring it.

For additional Java-related information, see "[Java Interfaces](#)" on [page 1](#) in the *SDK Reference Guide*

JSP Static Registration

You would choose static registration of providers if you want all applications to default to our (SafeNet) provider.

Once your client has externally logged in using `salogin` (see) in the Reference section of this document) or your own HSM-aware utility, any application would be able to use Luna product without being designed to login to the HSM Partition.

Edit the `java.security` file located in the `\jre\lib\security` directory of your Java SDK/JRE 1.6.x or 1.7.x installation to read as follows:

```
security.provider.1=sun.security.provider.Sun
security.provider.2=com.sun.net.ssl.internal.ssl.Provider
security.provider.3=com.safenetinc.luna.provider.LunaProvider
security.provider.4=com.sun.rsa.jca.Provider
security.provider.5=com.sun.crypto.provider.SunJCE
security.provider.6=sun.security.jgss.SunProvider
```

You can set our provider in first position for efficiency if Luna HSM operations are your primary mode. However, if your application needs to perform operations not supported by the `LunaProvider` (secure random generation or random publickey verification, for example) then it would receive error messages from the HSM and would need to handle those gracefully before resorting to providers further down the list. We have found that having our provider in third position works well for most applications.

The modifications in the "java.security" file are global, and they might result in the breaking of another application that uses the default `KeyPairGenerator` without logging into the Luna SA first. This consideration might argue for using dynamic registration, instead.

JSP Dynamic Registration

For your situation, you may prefer to employ dynamic registration of Providers, in order to avoid possible negative impacts on other applications running on the same machine. As well, the use of dynamic registration allows you to keep installation as straightforward as possible for your customers.

Compatibility

We formally test Luna HSMs and our Java provider with SUN JDK for all platforms except AIX, and with IBM JDK for the AIX platform. We have not had problems with OpenJDK, although it has not been part of our formal test suite. The Luna JCE provider is compliant with the JCE specification, and should work with any JVM that implements the Java language specification.

Occasional problems have been encountered with respect to IBM JSSE.

GNU JDK shipped with most Linux systems has historically been incomplete and not suitable.

Remove components

To uninstall the JSP component or the SDK component, you must uninstall Luna Client completely (see "HP-UX Luna Client Installation" on page 60), then re-run the installation script without selecting the unwanted component(s).

Interrupting the Installation

Do not interrupt the installation script in progress, and ensure that your host computer is served by an uninterruptible power supply (UPS). If you press [Ctrl] [C], or otherwise interrupt the installation (OS problem, power outage, other), some components will not be installed. It is not possible to resume an interrupted install process. The result of an interruption depends on where, in the process, the interruption occurred (what remained to install before the process was stopped).

As long as the `cryptoki` RPM package is installed, any subsequent installation attempt results in refusal with the message "A version of Luna Client is already installed."

If components are missing or are not working properly after an interrupted installation, or if you wish to install any additional components at a later date (following an interrupted installation, as described), you would need to uninstall everything first. If 'sh uninstall.sh' is unable to do it, then you must uninstall all packages manually.

Because interruption of the install.sh script is not recommended, and mitigation is possible, this is considered a low-likelihood corner case, fully addressed by these comments.

After Installation

When you have installed the software onto a Client, the next task is to configure the Luna HSM, as described in the *Configuration Guide*.

Linux Luna Client Installation

These instructions are tested for the Linux versions listed in the Customer Release Notes.

These instructions assume that you have already acquired the Luna Client software, either on CD/DVD or in the form of a downloaded .tar archive.

Applicability to specific versions of Linux is summarized in the Customer Release Notes for the current release.



Note: Before installing a Luna® system, confirm that the product you have received is in factory condition and has not been tampered with in transit. Refer to the Startup Guide included with your product shipment. If you have any questions about the condition of the product that you have received, please contact SafeNet Support (800)545 6608 or support@safenet-inc.com immediately

Each computer that connects to the Luna HSM appliance as a Client must have the cryptoki library, the vtl client shell and other utilities and supporting files installed.

Each computer that contains, or is connected to a Luna G5 or a Luna PCI-E HSM must have the cryptoki library and other utilities and supporting files installed.



Note: This example shows all the Luna Client products and components. Some items are not supported on all operating systems and therefore do not appear as you proceed through the installation script.

Do not install Luna client software on the same system as legacy Luna CA³, Luna CA4, Luna PCM, or Luna PCI software. The software is intended for modern/current Luna HSMs, Luna SA, Luna PCI-E, Luna G5, Luna (Remote) Backup HSM.

Prerequisites

Before starting the installation, ensure that you have satisfied the following prerequisites:

Random Number Generator (RNG) or Entropy Gathering Daemon (EGD)

Ensure that you have a Random Number Generator (RNG) or Entropy Gathering Daemon (EGD) on your system in one of the following locations:

- /dev/egd-pool
- /etc/egd-pool,
- /etc/entropy
- /var/run/egd-pool

RNG/EGD

Cryptographic algorithms, including those that assure the security of communication – such as in OpenSSL and other protocols – depend upon random numbers for the creation of strong keys and certificates. A readily available source of random data is the entropy that exists in complex computer processes. Utilities exist for every operating system, to gather bits of system entropy into a pool, which can then be used by other processes.

Windows and Linux have these installed by default. Other systems may or may not. See your system administrator.

You Need an Entropy Pool

In the case of Luna SA, the Luna Client administration tool (**vtl**) expects to find a source of randomness at **/dev/random**. If one is not found, **vtl** fails, because the link cannot be secured from the Client end.

If your system does have an entropy pool, but the random number generator (RNG) is not in the expected place, then you can create a symbolic link between the actual location and one of the following:

- `/dev/random`
- `/dev/egd-pool`
- `/etc/egd-pool`
- `/etc/entropy`
- `/var/run/egd-pool`

If your system does not have an entropy gathering daemon or random number generator, please direct your system administrator to install one, and point it to one of the named devices.

Alien with Debian

The Luna Client software is provided as RPM packages. If you are installing on a Debian system, you must have "alien" installed before beginning the Luna Client installation. The Luna Client installation script invokes the alien conversion of RPMs to DEB packages. The install script will stop with a message if you attempt to install on a Debian system without the alien package already installed.

Components Used to Build the Driver (Luna G5, PCI-E, and Remote Backup HSM)

If you are installing the Luna PCI-E, or Luna G5, or Luna Remote Backup HSM clients, ensure that the following items are installed:

- Kernel headers for build
- rpm-build package
- C and C++ compilers
- make command

These items are required because the driver module is built on Linux before it is installed. If one of these items is missing, the driver build will fail and the module will not be installed..

Installing the Client Software

It is recommended that you refer to the Luna HSM Customer Release Notes for any installation-related issues or instructions before you begin the following software installation process.



CAUTION: You must be logged in as **root** when you run the installation script.

By default, the Client programs are installed in the `"/usr/safenet/lunaclient"` directory.

To install the Luna client software on a Linux workstation

1. Log on to the client system, open a console or terminal window, and use **sudo** to gain administrative permissions for the installation.
2. If you have downloaded the Luna Client software as a `.tar` archive, skip to step 6.
3. Insert the DVD (mount it if you do not have automount).

4. Go to the DVD (**/cdrom** or whatever devicename your system uses) and the install directory for your architecture:

```
cd /cdrom/linux/32
```

or

```
cd /cdrom/linux/64
```



Note: Not all platforms are supported with each release, so the available install options might not match the list above.

5. Skip to step 9.
6. If you downloaded the software, copy or move the **.tar** archive (which usually has a name like "Luna Client_5.x.y-nn.tar") to a suitable directory where you can untar the archive and launch the installation script.
7. Extract the contents from the archive:

```
tar xvf <filename>.tar
```
8. Change directory to the software version suitable for your system (for example, under the **linux** subdirectory, in the **x86** directory, choose 32-bit or 64-bit according to your system requirement).

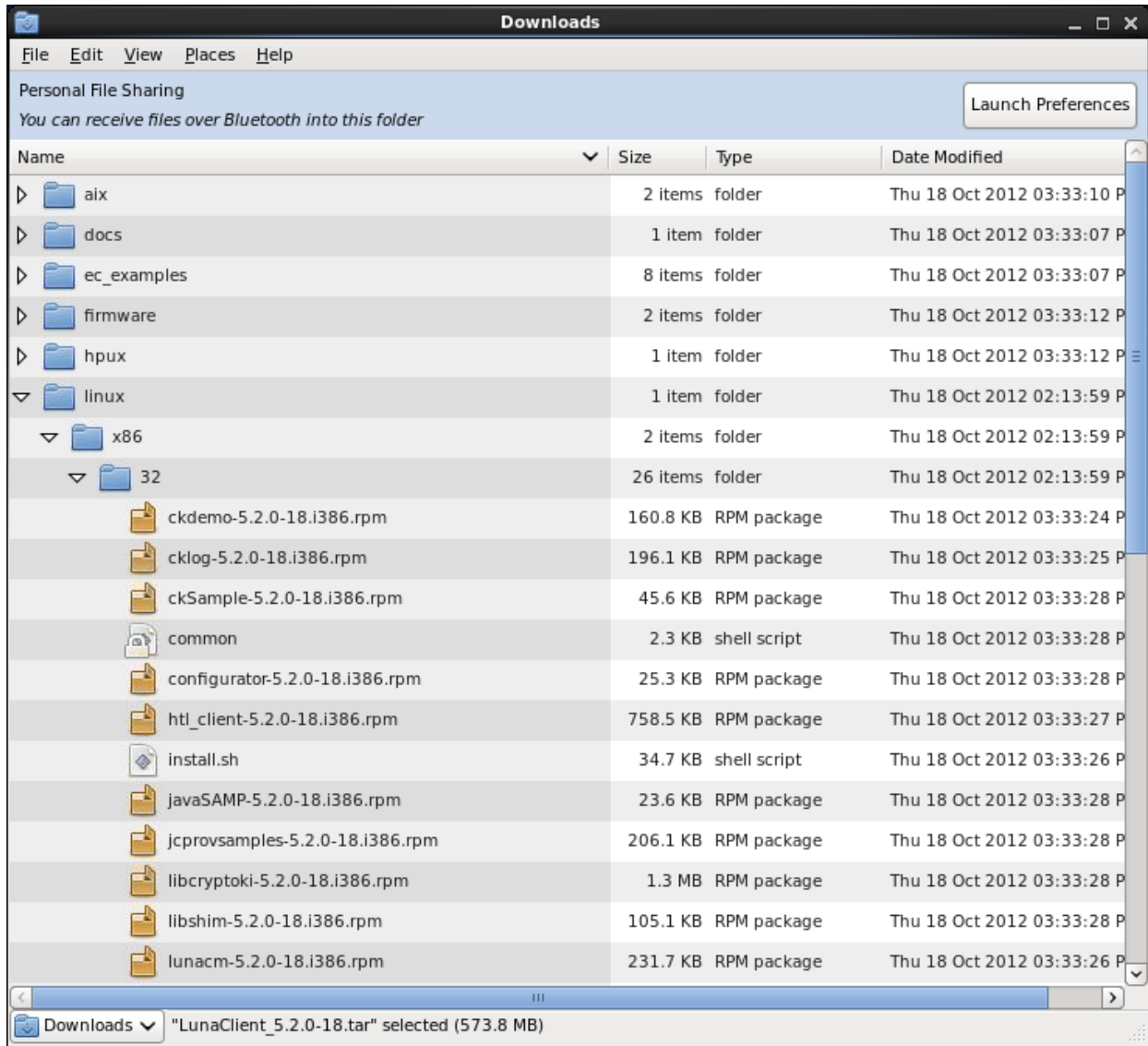

9. To see the help, or a list of available installer options, type:

```
./sh install.sh -? or ./sh install.sh --help
```

To install all available products and optional components, type:

```
./sh install.sh all
```

To selectively install individual products and optional components, type the command without arguments:

```
./sh install.sh
```

10. Type **y** if you agree to be bound by the license agreement.
11. A list of installable Luna products appears (might be different, depending on your platform). Select as many as you require, by typing the number of each (in any order) and pressing [Enter]. As each item is selected, the list updates, with a "*" in front of any item that has been selected. This example shows items 1 and 3 have been selected, and item 4 is about to be selected.

```

Products
Choose Luna Products to be installed
  * [1]: Luna SA
    [2]: Luna PCI-E
  * [3]: Luna G5
    [4]: Luna Remote Backup HSM
    [N|n]: Next
    [Q|q]: Quit
Enter selection: 4

```

12. When selection is complete, type "N" or "n" for "Next", and press [Enter]. If you wish to make a change, simply type a number again and press [Enter] to de-select a single item.
13. The next list is called "Advanced" and includes additional items to install. Some items might be pre-selected to provide the optimum Luna HSM experience for the majority of customers, but you can change any selection in the list. When the Components list is adjusted to your satisfaction, press [Enter].



Note: The installer includes the Luna SNMP Subagent as an option. If you select this option, you will need to move the SafeNet MIB files to the appropriate directory for your SNMP application after installation is complete, and you will need to start the SafeNet subagent and configure for use with your agent. See the *Administration Guide* for more information.

14. If the script detects an existing cryptoki library, it stops and suggests that you uninstall your previous Luna software before starting the Luna Client installation again.
15. The system installs all packages related to the products and any optional components that you selected.

As a general rule, do not modify the `Chrystoki.conf/crystoki.ini` file, unless directed to do so by SafeNet Customer Support. If you do modify the file, never insert TAB characters - use individual space characters. Avoid modifying the PED timeout settings. These are now hardcoded in the appliance, but the numbers in the `Chrystoki.conf` file must match.

Uninstalling the Luna HSM Client Software

```
cd /usr/safenet/lunaclient/bin
```

```
./sh uninstall.sh
```

Java

During the installation, the script provides the opportunity to install Luna Java components. If you select Java components, the Luna Java files are installed below `/usr/safenet/lunaclient/jsp/`. In order to use Java, you must have separately installed Java (JDK or run-time environment from the vendor of your choice) onto your system.

Copy the Luna Java library and jar files from their default location under `/usr/safenet/lunaclient/jsp/lib` to the Java environment directory, for example `/usr/jre/lib/ext`.

The exact directory might differ depending on where you obtained your Java system, the version, and any choices that you made while installing and configuring it.

For additional Java-related information, see "Java Interfaces" on page 1 in the *SDK Reference Guide*.

JSP Static Registration

You would choose static registration of providers if you want all applications to default to our (SafeNet) provider.

Once your client has externally logged in using salogin (see) in the Reference section of this document) or your own HSM-aware utility, any application would be able to use Luna product without being designed to login to the HSM Partition.

Edit the `java.security` file located in the `\jre\lib\security` directory of your Java SDK/JRE 1.6.x or 1.7.x installation to read as follows:

```
security.provider.1=sun.security.provider.Sun
security.provider.2=com.sun.net.ssl.internal.ssl.Provider
security.provider.3=com.safenetinc.luna.provider.LunaProvider
security.provider.4=com.sun.rsa.jca.Provider
security.provider.5=com.sun.crypto.provider.SunJCE
security.provider.6=sun.security.jgss.SunProvider
```

You can set our provider in first position for efficiency if Luna HSM operations are your primary mode. However, if your application needs to perform operations not supported by the `LunaProvider` (secure random generation or random publickey verification, for example) then it would receive error messages from the HSM and would need to handle those gracefully before resorting to providers further down the list. We have found that having our provider in third position works well for most applications.

The modifications in the "java.security" file are global, and they might result in the breaking of another application that uses the default `KeyPairGenerator` without logging into the Luna SA first. This consideration might argue for using dynamic registration, instead.

JSP Dynamic Registration

For your situation, you may prefer to employ dynamic registration of Providers, in order to avoid possible negative impacts on other applications running on the same machine. As well, the use of dynamic registration allows you to keep installation as straightforward as possible for your customers.

Compatibility

We formally test Luna HSMs and our Java provider with SUN JDK for all platforms except AIX, and with IBM JDK for the AIX platform. We have not had problems with OpenJDK, although it has not been part of our formal test suite. The Luna JCE provider is compliant with the JCE specification, and should work with any JVM that implements the Java language specification.

Occasional problems have been encountered with respect to IBM JSSE.

GNU JDK shipped with most Linux systems has historically been incomplete and not suitable.

Removing components

To uninstall the JSP component or the SDK component, you must uninstall Luna Client completely, then re-run the installation script without selecting the unwanted component(s).

```
sh uninstall.sh
```

[Ctrl] [C] - If you interrupt the installation

Do not interrupt the installation script in progress, and ensure that your host computer is served by an uninterruptible power supply (UPS). If you press [Ctrl] [C], or otherwise interrupt the installation (OS problem, power outage, other),

some components will not be installed. It is not possible to resume an interrupted install process. The result of an interruption depends on where, in the process, the interruption occurred (what remained to install before the process was stopped).

As long as the cryptoki RPM package is installed, any subsequent installation attempt results in refusal with the message "A version of Luna Client is already installed."

If components are missing or are not working properly after an interrupted installation, or if you wish to install any additional components at a later date (following an interrupted installation, as described), you would need to uninstall everything first. If 'sh uninstall.sh' is unable to do it, then you must uninstall all packages manually.

Because interruption of the install.sh script is not recommended, and mitigation is possible, this is considered a low-likelihood corner case, fully addressed by these comments.

Scripted or Unattended Installation

If you prefer to run the installation from a script, rather than interactively, run the command with the options `-p <list of Luna products>` and `-c <list of Luna components>`. To see the syntax, run the command with `--help` like this:

```
[myhost]$ sh ../Luna Client_5.3.0-5x/linux/64/install.sh --help
Installing from ../Luna Client_5.3.0-x/linux/64
```

At least one product should be specified.

usage:

```
install.sh      - Luna Client install through menu
install.sh help - Display scriptable install options
install.sh all  - Complete Luna Client install
```

```
install.sh -p [sa|pci|g5|rb] [-c sdk|jsp|jcprov|ldpc|snmp]
```

```
-p <list of Luna products>
```

```
-c <list of Luna components> - Optional. All components are installed if not provided
```

Luna products options

```
sa      - Luna SA
pci     - Luna PCI-E
g5      - Luna G5
rb      - Luna Remote Backup HSM
```

Luna components options

```
sdk     - Luna SDK
jsp     - Luna JSP (Java)
jcprov  - Luna JCPROV (Java)
ldpc    - Crypto Command Center Provisioning Client
snmp    - Luna SNMP subagent
```

```
[myhost]$
```

For scripted/automated installation, your script will need to capture and respond to the License Agreement prompt, and to the confirmation prompt. For example:

```
[myhost]$ ./install.sh all
Installing from /home/me/Downloads/Luna Client_5.3.0/linux/64
```

```
IMPORTANT: The terms and conditions of use outlined in the software
license agreement (Document #008-010005-001_053110) shipped with the product
```

("License") constitute a legal agreement between you and SafeNet Inc. Please read the License contained in the packaging of this product in its entirety before installing this product.

Do you agree to the License contained in the product packaging?

If you select 'yes' or 'y' you agree to be bound by all the terms and conditions set out in the License.

If you select 'no' or 'n', this product will not be installed.

(y/n) **y**

Complete Luna Client will be installed. This includes Luna SA, Luna PCI-E, Luna G5 AND Luna Remote Backup HSM.

Select 'yes' or 'y' to proceed with the install.

Select 'no' or 'n', to cancel this install.

Continue (y/n)? **y**

For example, to automate installation for our testing, we use:

```
if product == 'all':
cmd = '/bin/bash %s %s'%(install_cmd, product) # install.sh all
```

SUSE Linux on IBM PPC

JCE un-restriction files must be downloaded from IBM, not from SUN, for this platform. Attempting to use SUN JCE un-restriction files on IBM PowerPC systems with SUSE Linux causes signing errors with Java 5 and Java 6.

32-bit Client on 64-bit RedHat 6

While no errors normally appear when installing 64-bit client on 64-bit RedHat 6, some preparation is required to avoid installation errors when installing 32-bit Client on 64-bit OS. Do the following:

- `yum install glibc.i686`
- `yum upgrade libstdc++`
- `yum install libstdc++.i686`
- `yum install libgcc.i686`

Then run the 32-bit installer

./install.sh

Failure to perform those steps before launching the installer can result in output like the following:

```
Installing the Luna Client 5.3.0-5...
Adding new version of configurator
/home/builds/Luna Client/CLT_SDK/5.3.0/Luna Client_5.3.0-5/Luna Client_5.3.0-5/linux/32
Preparing... ##### [100%]
1:configurator ##### [100%]
Adding new version of libcryptoki
/home/builds/Luna Client/CLT_SDK/5.3.0/Luna Client_5.3.0-5/Luna Client_5.3.0-5/linux/32
Preparing... ##### [100%]
```

```

1:libcryptoki ##### [100%]
Checking for /etc/Chrystoki.conf.rpmsave
Using new /etc/Chrystoki.conf
/var/tmp/rpm-tmp.ndfBQQ: /usr/safenet/lunaclient/bin/configurator: /lib/ld-linux.so.2: bad ELF
interpreter: No such file or directory
/var/tmp/rpm-tmp.ndfBQQ: /usr/safenet/lunaclient/bin/configurator: /lib/ld-linux.so.2: bad ELF
interpreter: No such file or directory
/var/tmp/rpm-tmp.ndfBQQ: /usr/safenet/lunaclient/bin/configurator: /lib/ld-linux.so.2: bad ELF
interpreter: No such file or directory
/var/tmp/rpm-tmp.ndfBQQ: /usr/safenet/lunaclient/bin/configurator: /lib/ld-linux.so.2: bad ELF
interpreter: No such file or directory
/var/tmp/rpm-tmp.ndfBQQ: /usr/safenet/lunaclient/bin/configurator: /lib/ld-linux.so.2: bad ELF
interpreter: No such file or directory
/var/tmp/rpm-tmp.ndfBQQ: /usr/safenet/lunaclient/bin/configurator: /lib/ld-linux.so.2: bad ELF
interpreter: No such file or directory
/var/tmp/rpm-tmp.ndfBQQ: /usr/safenet/lunaclient/bin/configurator: /lib/ld-linux.so.2: bad ELF
interpreter: No such file or directory
/var/tmp/rpm-tmp.ndfBQQ: /usr/safenet/lunaclient/bin/configurator: /lib/ld-linux.so.2: bad ELF
interpreter: No such file or directory
/var/tmp/rpm-tmp.ndfBQQ: /usr/safenet/lunaclient/bin/configurator: /lib/ld-linux.so.2: bad ELF
interpreter: No such file or directory
/var/tmp/rpm-tmp.ndfBQQ: /usr/safenet/lunaclient/bin/configurator: /lib/ld-linux.so.2: bad ELF
interpreter: No such file or directory
/var/tmp/rpm-tmp.ndfBQQ: /usr/safenet/lunaclient/bin/configurator: /lib/ld-linux.so.2: bad ELF
interpreter: No such file or directory
/var/tmp/rpm-tmp.ndfBQQ: /usr/safenet/lunaclient/bin/configurator: /lib/ld-linux.so.2: bad ELF
interpreter: No such file or directory
/var/tmp/rpm-tmp.ndfBQQ: /usr/safenet/lunaclient/bin/configurator: /lib/ld-linux.so.2: bad ELF
interpreter: No such file or directory
/var/tmp/rpm-tmp.ndfBQQ: /usr/safenet/lunaclient/bin/configurator: /lib/ld-linux.so.2: bad ELF
interpreter: No such file or directory
/var/tmp/rpm-tmp.ndfBQQ: /usr/safenet/lunaclient/bin/configurator: /lib/ld-linux.so.2: bad ELF
interpreter: No such file or directory
/var/tmp/rpm-tmp.ndfBQQ: /usr/safenet/lunaclient/bin/configurator: /lib/ld-linux.so.2: bad ELF
interpreter: No such file or directory
/var/tmp/rpm-tmp.ndfBQQ: /usr/safenet/lunaclient/bin/configurator: /lib/ld-linux.so.2: bad ELF
interpreter: No such file or directory
Adding new version of libshim
/home/builds/Luna Client/CLT_SDK/5.3.0/Luna Client_5.3.0-5/Luna Client_5.3.0-5/linux/32
Preparing... ##### [100%]
1:libshim ##### [100%]
Adding new version of lunacm
/home/builds/Luna Client/CLT_SDK/5.3.0/Luna Client_5.3.0-5/Luna Client_5.3.0-5/linux/32
Preparing... ##### [100%]
1:lunacm ##### [100%]
Adding new version of lunacmu
/home/builds/Luna Client/CLT_SDK/5.3.0/Luna Client_5.3.0-5/Luna Client_5.3.0-5/linux/32
Preparing... ##### [100%]
1:lunacmu ##### [100%]
Adding new version of ckdemo
/home/builds/Luna Client/CLT_SDK/5.3.0/Luna Client_5.3.0-5/Luna Client_5.3.0-5/linux/32
Preparing... ##### [100%]
1:ckdemo ##### [100%]
Adding new version of multitoken
/home/builds/Luna Client/CLT_SDK/5.3.0/Luna Client_5.3.0-5/Luna Client_5.3.0-5/linux/32
Preparing... ##### [100%]
1:multitoken ##### [100%]
Adding new version of cklog
/home/builds/Luna Client/CLT_SDK/5.3.0/Luna Client_5.3.0-5/Luna Client_5.3.0-5/linux/32
Preparing... ##### [100%]
1:cklog ##### [100%]
Adding new version of salogin
/home/builds/Luna Client/CLT_SDK/5.3.0/Luna Client_5.3.0-5/Luna Client_5.3.0-5/linux/32
Preparing... ##### [100%]
1:salogin ##### [100%]
Adding new version of vtl
/home/builds/Luna Client/CLT_SDK/5.3.0/Luna Client_5.3.0-5/Luna Client_5.3.0-5/linux/32

```

```

Preparing... ##### [100%]
1:vtl ##### [100%]
Adding new version of htl_client
/home/builds/Luna Client/CLT_SDK/5.3.0/Luna Client_5.3.0-5/Luna Client_5.3.0-5/linux/32
Preparing... ##### [100%]
1:htl_client ##### [100%]
/var/tmp/rpm-tmp.bLgGlF: /usr/safenet/lunaclient/bin/configurator: /lib/ld-linux.so.2: bad ELF
interpreter: No such file or directory
Starting htl_client:/etc/init.d/htlc_service: /usr/safenet/lunaclient/htl/htl_client: /lib/ld-
linux.so.2: bad ELF interpreter: No such file or directory
FAILED
warning: %post(htl_client-5.3.0-5.i386) scriptlet failed, exit status 1
Adding new version of javaSAMP
/home/builds/Luna Client/CLT_SDK/5.3.0/Luna Client_5.3.0-5/Luna Client_5.3.0-5/linux/32
Preparing... ##### [100%]
1:javaSAMP ##### [100%]
Adding new version of ckSample
/home/builds/Luna Client/CLT_SDK/5.3.0/Luna Client_5.3.0-5/Luna Client_5.3.0-5/linux/32
Preparing... ##### [100%]
1:ckSample ##### [100%]

```

If the installation script proceeds to the end, with the above errors, the installation appears successful, but you are unable to create certs. Re-do.

After Installation

When you have installed the software onto a Client, the next task is to configure the Luna HSM, as described in the *Configuration Guide*.

Solaris Luna Client Installation

These instructions assume that you have already acquired the Luna client software, either on CD/DVD or in the form of a downloaded .tar archive.

Applicability to specific versions of Solaris is summarized in the Customer Release Notes for the current release.



Note: Before installing a Luna system, you should confirm that the product you have received is in factory condition and has not been tampered with in transit. Refer to the Startup Guide included with your product shipment. If you have any questions about the condition of the product that you have received, contact SafeNet Support.

Each computer that connects to the Luna HSM appliance as a client must have the cryptoki library, the vtl client shell and other utilities and supporting files installed.

Each computer that contains, or is connected to a Luna G5 or a Luna PCI-E HSM must have the cryptoki library and other utilities and supporting files installed.



Note: This example shows all the Luna client products and components. Some items are not supported on all operating systems and therefore do not appear as you proceed through the installation script.

Do not install Luna client software on the same system as legacy Luna CA³, Luna CA4, Luna PCM, or Luna PCI software. The software is intended for modern/current Luna HSMs, Luna SA, Luna PCI-E, Luna G5, Luna (Remote) Backup HSM.

Prerequisites

Before starting the installation, ensure that you have satisfied the following prerequisites:

Random Number Generator (RNG) or Entropy Gathering Daemon (EGD)

Ensure that you have a Random Number Generator (RNG) or Entropy Gathering Daemon (EGD) on your system in one of the following locations:

- /dev/egd-pool
- /etc/egd-pool,
- /etc/entropy
- /var/run/egd-pool

RNG/EGD

Cryptographic algorithms, including those that assure the security of communication – such as in OpenSSL and other protocols – depend upon random numbers for the creation of strong keys and certificates. A readily available source of random data is the entropy that exists in complex computer processes. Utilities exist for every operating system, to gather bits of system entropy into a pool, which can then be used by other processes.

Windows and Linux have these installed by default. Other systems may or may not. See your system administrator.

You Need an Entropy Pool

In the case of Luna SA, the Luna Client administration tool (**vtl**) expects to find a source of randomness at **/dev/random**. If one is not found, **vtl** fails, because the link cannot be secured from the Client end.

If your system does have an entropy pool, but the random number generator (RNG) is not in the expected place, then you can create a symbolic link between the actual location and one of the following:

- `/dev/random`
- `/dev/egd-pool`
- `/etc/egd-pool`
- `/etc/entropy`
- `/var/run/egd-pool`

If your system does not have an entropy gathering daemon or random number generator, please direct your system administrator to install one, and point it to one of the named devices.

Installing the Client Software

It is recommended that you refer to the Luna HSM Customer Release Notes for any installation-related issues or instructions before you begin the following software installation process.



CAUTION: You must be logged in as **root** when you run the installation script.

By default, the Client programs are installed in the **/opt/safenet/lunaclient/bin** directory.

To install the Luna client software on a Linux workstation

1. Log on to the client system, open a console or terminal window, and use **su** to gain administrative permissions for the installation.
2. Access the Luna client software:

DVD	<ol style="list-style-type: none"> 1. Insert the DVD (mount it if you do not have automount). 2. Go to the DVD (/cdrom or whatever device name your system uses)
Tar archive	<ol style="list-style-type: none"> 1. Copy or move the .tar archive to a suitable directory where you can untar the archive and launch the installation script. 2. Extract the contents from the archive: tar xvf <filename>.tar

3. Go to the install directory for your architecture:

Architecture	Path
Solaris Sparc 32-bit	<dvd_or_tarball_path>/solaris/sparc/32
Solaris Sparc 64-bit	<dvd_or_tarball_path>/solaris/sparc/64
Solaris x86 32-bit	<dvd_or_tarball_path>/solaris/x86/32
Solaris x86 64-bit	<dvd_or_tarball_path>/solaris/x86/64



Note: Not all platforms are supported with each release, so the available install options might not match the list above. Refer to the Customer Release Notes for more information.

- To see the help, or a list of available installer options, type:

sh install.sh -? or **sh install.sh --help**

To install all available products and optional components, type:

sh install.sh all

To selectively install individual products and optional components, type the command without arguments:

sh install.sh

- Type **y** if you agree to be bound by the license agreement.
- A list of installable Luna products is displayed (might be different, depending on your platform). Select as many as you require, by typing the number of each (in any order) and pressing [Enter]. As each item is selected, the list updates, with a "*" in front of any item that has been selected. The following example shows that items 1 and 3 have been selected, and item 4 is about to be selected.

```
Products
Choose Luna Products to be installed
* [1]: Luna SA
  [2]: Luna PCI-E
* [3]: Luna G5
  [4]: Luna Remote Backup HSM
  [N|n]: Next
  [Q|q]: Quit
Enter selection: 4
```

- When the selection is complete, type "N" or "n" for "Next", and press [Enter]. If you wish to make a change, simply type a number again and press [Enter] to de-select a single item.
- The next list is called "Advanced" and includes additional items to install. Some items might be pre-selected to provide the optimum Luna HSM experience for the majority of customers, but you can change any selection in the list. When the Components list is adjusted to your satisfaction, press [Enter].



Note: The installer includes the Luna SNMP Subagent as an option. If you select this option, you will need to move the SafeNet MIB files to the appropriate directory for your SNMP application after installation is complete, and you will need to start the SafeNet subagent and configure for use with your agent. See the *Administration Guide* for more information.

- If the script detects an existing cryptoki library, it stops and suggests that you uninstall your previous Luna software before starting the Luna Client installation again.
- The system installs all packages related to the products and any optional components that you selected.

As a general rule, do not modify the `Chrystoki.conf/crystoki.ini` file, unless directed to do so by SafeNet Customer Support. If you do modify the file, never insert TAB characters - use individual space characters. Avoid modifying the PED timeout settings. These are now hardcoded in the appliance, but the numbers in the `Chrystoki.conf` file must match.

Uninstalling the Luna HSM Client Software

```
cd /opt/safenet/lunaclient/bin
```

```
sh uninstall.sh
```

Java

During the installation, the script provides the opportunity to install Luna Java components. If you select Java components, the Luna Java files are installed below `/opt/safenet/lunaclient/jsp/`. In order to use Java, you must have separately installed Java (JDK or run-time environment from the vendor of your choice) onto your system.

Copy the Luna Java library and jar files from their default location under `/opt/safenet/lunaclient/jsp/lib` to the Java environment directory, for example `/opt/jre/lib/ext`.

The exact directory might differ depending on where you obtained your Java system, the version, and any choices that you made while installing and configuring it.

For additional Java-related information, see "[Java Interfaces](#)" on page 1 in the *SDK Reference Guide*.

JSP Static Registration

You would choose static registration of providers if you want all applications to default to our (SafeNet) provider.

Once your client has externally logged in using `salogin` (see) in the Reference section of this document) or your own HSM-aware utility, any application would be able to use Luna product without being designed to login to the HSM Partition.

Edit the `java.security` file located in the `\jre\lib\security` directory of your Java SDK/JRE 1.6.x or 1.7.x installation to read as follows:

```
security.provider.1=sun.security.provider.Sun
security.provider.2=com.sun.net.ssl.internal.ssl.Provider
security.provider.3=com.safenetinc.luna.provider.LunaProvider
security.provider.4=com.sun.rsa.jca.Provider
security.provider.5=com.sun.crypto.provider.SunJCE
security.provider.6=sun.security.jgss.SunProvider
```

You can set our provider in first position for efficiency if Luna HSM operations are your primary mode. However, if your application needs to perform operations not supported by the `LunaProvider` (secure random generation or random publickey verification, for example) then it would receive error messages from the HSM and would need to handle those gracefully before resorting to providers further down the list. We have found that having our provider in third position works well for most applications.

The modifications in the "java.security" file are global, and they might result in the breaking of another application that uses the default `KeyPairGenerator` without logging into the Luna SA first. This consideration might argue for using dynamic registration, instead.

JSP Dynamic Registration

For your situation, you may prefer to employ dynamic registration of Providers, in order to avoid possible negative impacts on other applications running on the same machine. As well, the use of dynamic registration allows you to keep installation as straightforward as possible for your customers.

Compatibility

We formally test Luna HSMs and our Java provider with SUN JDK for all platforms except AIX, and with IBM JDK for the AIX platform. We have not had problems with OpenJDK, although it has not been part of our formal test suite. The Luna JCE provider is compliant with the JCE specification, and should work with any JVM that implements the Java language specification.

Occasional problems have been encountered with respect to IBM JSSE.

GNU JDK shipped with most Linux systems has historically been incomplete and not suitable.

Removing components

To uninstall the JSP component or the SDK component, you must uninstall Luna Client completely, then re-run the installation script without selecting the unwanted component(s).

sh uninstall.sh

[Ctrl] [C] - If you interrupt the installation

Do not interrupt the installation script in progress, and ensure that your host computer is served by an uninterruptible power supply (UPS). If you press [Ctrl] [C], or otherwise interrupt the installation (OS problem, power outage, other), some components will not be installed. It is not possible to resume an interrupted install process. The result of an interruption depends on where, in the process, the interruption occurred (what remained to install before the process was stopped).

As long as the cryptoki RPM package is installed, any subsequent installation attempt results in refusal with the message "A version of Luna Client is already installed."

If components are missing or are not working properly after an interrupted installation, or if you wish to install any additional components at a later date (following an interrupted installation, as described), you would need to uninstall everything first. If 'sh uninstall.sh' is unable to do it, then you must uninstall all packages manually.

Because interruption of the install.sh script is not recommended, and mitigation is possible, this is considered a low-likelihood corner case, fully addressed by these comments.

After Installation

When you have installed the software onto a Client, the next task is to configure the Luna HSM, as described in the *Configuration Guide*.

Windows Luna Client Installation

Applicability to specific versions of Windows is summarized in the Customer Release Notes for this release.



Note: Before installing a Luna® system, you should confirm that the product you have received is in factory condition and has not been tampered with in transit. Refer to the Startup Guide included with your product shipment. If you have any questions about the condition of the product that you have received, please contact SafeNet Support (800)545 6608 or support@safenet-inc.com immediately.

Required Client Software

Each computer that connects to the Luna SA as a Client must have the cryptoki library, the vtl client shell and other utilities and supporting files installed.

Each computer that contains, or is connected to a Luna PCI-E or a Luna G5 HSM must have the cryptoki library and other utilities and supporting files installed.



Note: .NET framework - before installing Luna Client on Windows 2012 platform, install Microsoft .NET framework version 3.5, first. You can have other versions of .NET on your system (there is no conflict), but 3.5 is needed for Luna Client to launch HTL on Windows 2012. For additional information see "Windows 2012 Luna Client Supplemental Configuration" on page 94. On Windows Server 2008, Luna Client installs and HTL works without additional Windows components.

Installing the Luna Client Software

The supported Windows servers are 64-bit. They allow running of 32-bit or 64-bit applications.

For compatibility of our HSMs with Windows in general, we provide both 32-bit and 64-bit libraries for use with your applications as appropriate, but our supplied tools (lunacm, cmu, multitoken, etc.) are 64-bit versions only. This is because 64-bit tools are all that is needed on a 64-bit OS, but we mention it in case you were looking for 32-bit equivalents - there aren't any because none are needed.

For compatibility of our HSMs with Windows CAPI we have Luna CSP, and for the newer Windows CNG we have Luna KSP. If you are using either, then a section near the end of this chapter has additional specific instructions.

Interactive (prompted) and non-interactive (no prompts) installation options are available.

To install the Luna client software

1. Log into Windows as "Administrator", or as a user with administrator privileges (see Troubleshooting tips, below).
2. Insert the Luna Client Software DVD into your optical drive.
3. Click **Start > Run** and then type:

d:\windows\64\Luna Client.msi

where "d" is your CDROM drive

or use Explorer to navigate the CD directories and double click the appropriate **Luna Client.msi**.



Note: The installer is 64-bit only. If you have 32-bit applications, proceed with the 64-bit installation, then see "Using 32-bit Applications With the Luna Client " on page 88.

- At the Welcome screen, click **Next**.

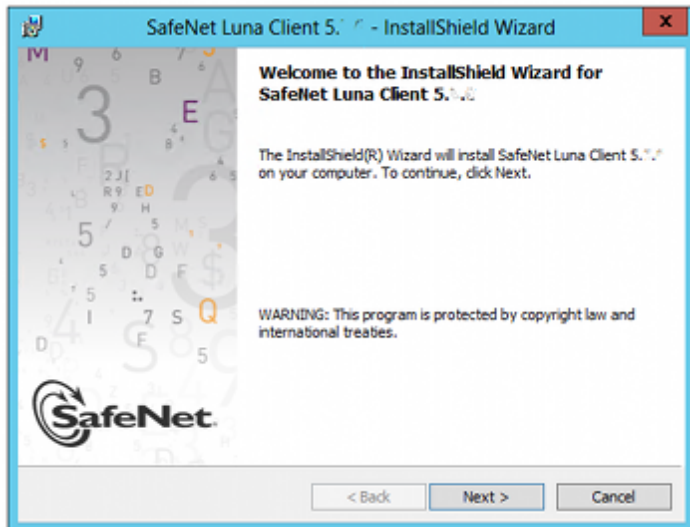

- Accept the software license agreement.

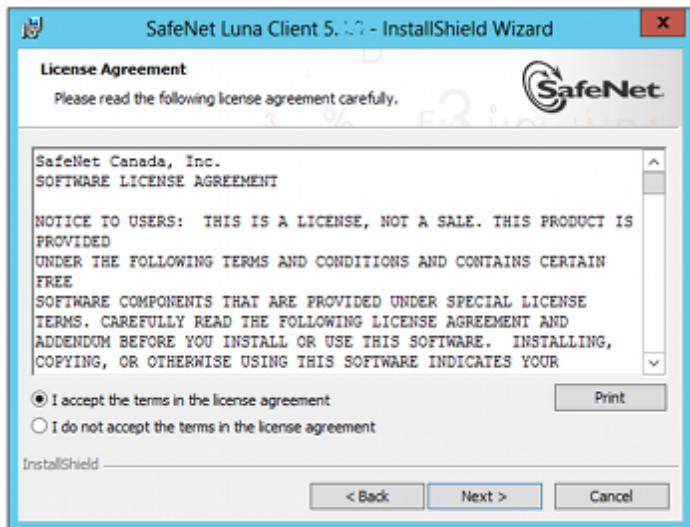

- In the **Choose Destination Location** dialog, accept the default that is offered, or make a change if you prefer.

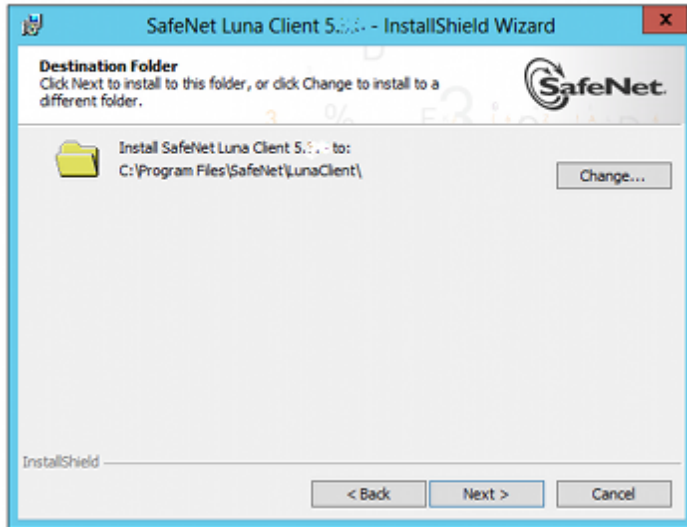

- Click to select any of the Luna Product software options that you wish to install. Any that are marked with a red "X" are currently de-selected and will not be installed when you proceed. You must accept at least the major feature for your HSM. You can select all, if you wish - there is no conflict.

The installer includes the Luna SNMP Subagent as an option with any of the Luna HSMs, except Luna SA (which has agent and subagent built in). For any of Luna PCI-E, Luna G5, or Luna Backup HSMs, include the subagent with any of the products, if desired - it doesn't matter which; it's the same subagent, and it goes to the same location on your hard disk.

After installation is complete, you will need to move the SafeNet MIB files to the appropriate directory for your SNMP application, and you will need to start the SafeNet subagent and configure for use with your agent, as described in the *Administration Guide*.

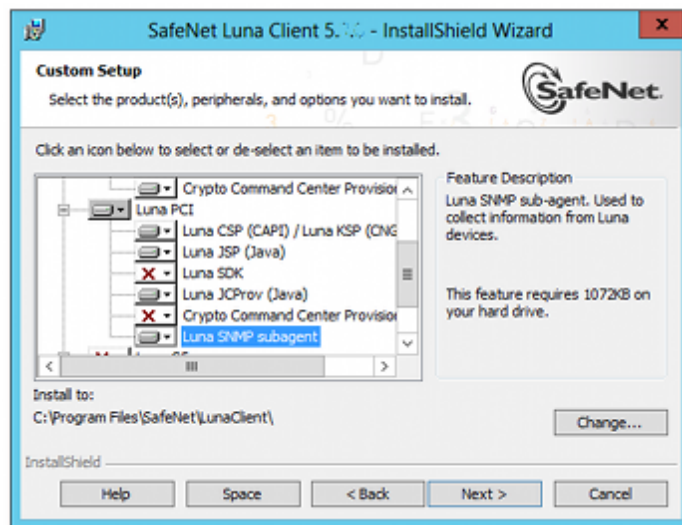

- On the **Ready to Install** page click **Install**.

If you wish to modify any of your previous selections, you can still click **Back** to see previous pages. Once you click **Install**, you are committed to the installation.

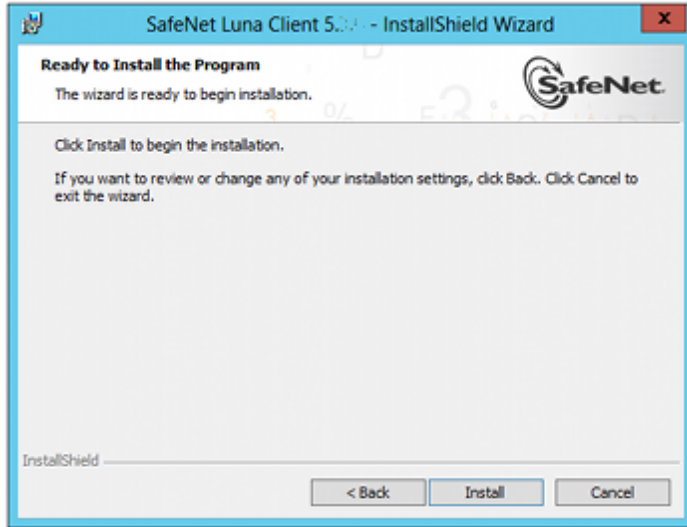

9. If Windows presents a security notice asking if you wish to install the device driver from SafeNet, click **Install** to accept.



Note: If you choose not to install the driver, your Luna Client cannot function with any locally connected Luna hardware (which includes Luna PCI-E, Luna G5, or Luna [Remote] Backup HSMs).

10. When the installation completes, click **Finish**.

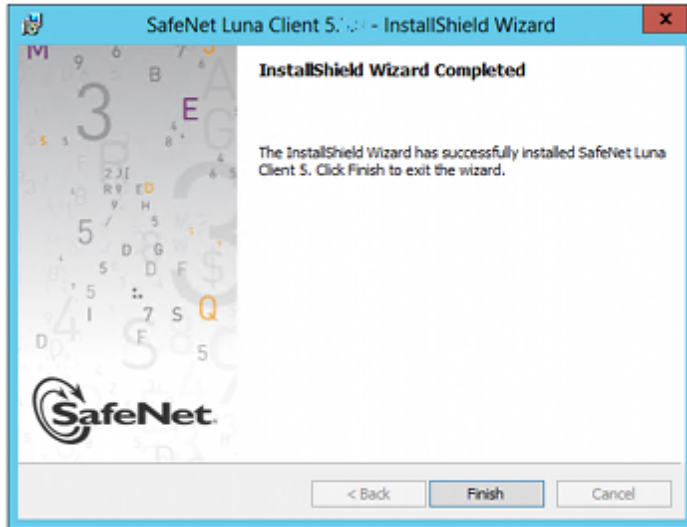

As a general rule, do not modify the `Chrystoki.conf/crystoki.ini` file, unless directed to do so by SafeNet Customer Support. If you do modify the file, never insert TAB characters - use individual space characters. Avoid modifying the PED timeout settings. These are now hardcoded in the appliance, but the numbers in the `Chrystoki.conf` file must match.

Using `msiexec` for scripted or unattended installation of the Luna Client

You can use the `msiexec` command to install the Luna client from the command line, or from a script. The `msiexec` command includes various command line switches (see the Microsoft documentation for details) that allow you to install the Luna client with varying levels of user interaction, including a quiet mode (`/qn`) that requires no user interaction.

However, since the Luna client includes a device driver, the following confirmation dialog is displayed when you install the Luna client using the `msiexec` command, regardless of the command line switches you use:

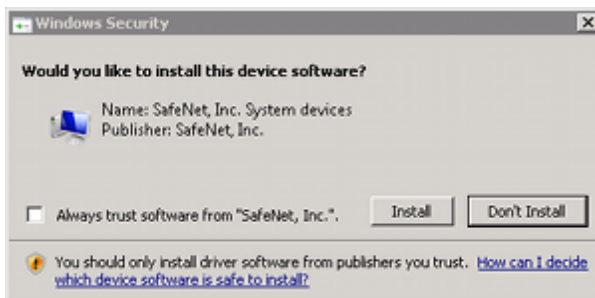

If you check the **Always trust software from "SafeNet, Inc."** checkbox, this dialog will not be displayed on subsequent installs, allowing for a truly "silent" install that requires no user interaction. That option was introduced with Windows 2008.

For more detailed information, see "[Scripted / Unattended Installation on Windows](#)" on page 97.

Java

During the installation, if you allow our Java Security Provider to be installed, the Luna Java files are installed below **C:\Program Files\Luna Client\JSP\lib**. In order to use our JSP, you must have separately installed Java (JDK or run-time environment from the vendor of your choice) onto your system.

Copy the Luna Java files from their default location under **C:\Program Files\SafeNet\Luna Client\JSP\lib** to the Java environment directory, for example **C:\Program Files\Java\jre6\lib\ext**.



Note: The exact directory might differ depending on where you obtained your Java system, the version, and any choices that you made while installing and configuring it.

Java 7 Library Path Issue

SafeNet has traditionally recommended that you put **LunaAPI.dll** in the `<java install dir>/lib/ext` folder.

However, Java 7 for Windows has removed this directory from the Java library path. As a result, when a Java 7 application on Windows uses the Luna provider, it cannot find the **LunaAPI.dll** library, causing the application to fail.

To address this problem, we suggest that you use one of the following methods to add **LunaAPI.dll** to the Java 7 search path:

- Put **LunaAPI.dll** in an arbitrary folder and add that folder to the system path. Java 7 will search the system path for **LunaAPI.dll**.
- Put **LunaAPI.dll** in the Windows system folder. This folder varies by operating system and DLL type, as follows:
 - - 32-bit Windows, 32-bit **LunaAPI.dll**: C:\Windows\System32
 - - 64-bit Windows, 64-bit **LunaAPI.dll**: C:\Windows\System32
 - - 64-bit Windows, 32-bit **LunaAPI.dll**: C:\Windows\SysWOW64

For additional Java-related information, see "[Java Interfaces](#)" on page 1 in the *SDK Reference Guide*.

JSP Static Registration

You would choose static registration of providers if you want all applications to default to our (SafeNet) provider.

Once your client has externally logged in using `salogin` (see) in the Reference section of this document) or your own HSM-aware utility, any application would be able to use Luna product without being designed to login to the HSM Partition.

Edit the `java.security` file located in the `\jre\lib\security` directory of your Java SDK/JRE 1.6.x or 1.7.x installation to read as follows:

```
security.provider.1=sun.security.provider.Sun
security.provider.2=com.sun.net.ssl.internal.ssl.Provider
security.provider.3=com.safenetinc.luna.provider.LunaProvider
security.provider.4=com.sun.rsa.jca.Provider
security.provider.5=com.sun.crypto.provider.SunJCE
security.provider.6=sun.security.jgss.SunProvider
```

You can set our provider in first position for efficiency if Luna HSM operations are your primary mode. However, if your application needs to perform operations not supported by the `LunaProvider` (secure random generation or random

publickey verification, for example) then it would receive error messages from the HSM and would need to handle those gracefully before resorting to providers further down the list. We have found that having our provider in third position works well for most applications.

The modifications in the "java.security" file are global, and they might result in the breaking of another application that uses the default KeyPairGenerator without logging into the Luna SA first. This consideration might argue for using dynamic registration, instead.

JSP Dynamic Registration

For your situation, you may prefer to employ dynamic registration of Providers, in order to avoid possible negative impacts on other applications running on the same machine. As well, the use of dynamic registration allows you to keep installation as straightforward as possible for your customers.

Compatibility

We formally test Luna HSMs and our Java provider with SUN JDK for all platforms except AIX, and with IBM JDK for the AIX platform. We have not had problems with OpenJDK, although it has not been part of our formal test suite. The Luna JCE provider is compliant with the JCE specification, and should work with any JVM that implements the Java language specification.

Occasional problems have been encountered with respect to IBM JSSE.

GNU JDK shipped with most Linux systems has historically been incomplete and not suitable.

CSP and KSP

Luna CSP allows you to use the Luna HSM with Microsoft CAPI, which is supported on 32-bit and on 64-bit Windows.

Luna KSP allows you to use the Luna HSM with Microsoft CNG, which is newer, has additional functions, and supersedes CAPI.

Both of these require modifications to the Windows Registry.

Luna CSP

For Luna CSP, the utility **register.exe** takes care of the registry.

Just remember to run the 64-bit version, the 32-bit version, or both, depending on the applications you are running.

- Register the csp dll:
register.exe /library
- Register the partition:
register <no arguments>

Luna KSP

For Luna KSP, the utility **KspConfig.exe** takes care of the registry. Follow instructions for the use of the graphical KspConfig.exe as described in "KSP for CNG" on page 1 in the *SDK Reference Guide*. Just remember to run the 64-bit version, the 32-bit version, or both, depending on the applications you are running.



Note: The **cryptoki.ini** file, which specifies many configuration settings for your HSM and related software, includes a line that specifies the path to the appropriate libNT for use with your application(s). Verify that the path is correct



Note: If Luna CSP (CAPI) / Luna KSP(CNG) is selected at installation time then the **SafeNetKSP.dll** file is installed in these two locations:

- **C:\Windows\System32** (used for 64-bit KSP)
- **C:\Windows\SysWOW64** (used for 32-bit KSP)

Using 32-bit Applications With the Luna Client

Beginning with version 5.2, SafeNet discontinued Luna Client support for Windows 32-bit operating systems. We continue to supply 32-bit libraries that can be used on 64-bit Windows OS to support your older 32-bit client applications. However, our Luna Client tools (lunacm, vtl, etc.) are 64-bit binary files, only.

Luna Client 32-bit libraries (**cryptoki.dll**, **cklog.dll**, etc.) and versions of CSP and KSP libraries and tools are installed in the **C:\Program Files\SafeNet\Luna Client\win32** directory.

The **win32** directory content is as follows:

- cklog201.dll
- cklog201.dll.sig
- cryptoki.dll
- cryptoki.dll.sig
- shim.dll
- shim.dll.sig
- **jsp** directory which contains:
 - LunaAPI.dll

If the Luna CSP (CAPI) / Luna KSP(CNG) feature is installed, the following are also installed under **win32**:

- csp directory which contains:
 - keymap
 - LunaCSP.dll
 - LunaCSP.sig
 - ms2Luna
 - register
- KSP directory that contains:
 - kspcmd
 - KspConfig
 - ksputil
 - ms2Luna

In order to properly use the 32-bit library and tools on 64-bit systems there are two basic approaches:

Direct loading of library

Set your application to load the 32-bit library installed under the win32 directory, and run your application. For an example on how to load the cryptoki library dynamically, please refer to the Luna SDK.

This should work for any application that directly points to the needed library, and represents the majority of customer applications.

Loading the library via the configuration file

If you require your 32-bit Windows application to run on 64-bit Windows and your application uses the `crystoki.ini` to find the location of the cryptoki library (such as applications that use `ckbridge` - no longer distributed - or that use CSP), we recommend creating a new copy of the `crystoki.ini` file under the win32 directory to point to the 32-bit cryptoki library as described below:

- Install Luna Client and configure the HSM or SA client as you would normally do.
- Create a copy of the `crystoki.ini` file and store it in the win32 directory.
- Modify the LibNT entry in the file (the copy in the win32 directory) to point to the `cryptoki.dll` library located in the win32 directory
`LibNT=C:\Program Files\SafeNet\Luna Client\win32\cryptoki.dll`
- Open a new DOS prompt (to be used to run your application).
- Set the `ChrystokiConfigurationPath` environment variable to point to the win32 directory set
`ChrystokiConfigurationPath= C:\Program Files\SafeNet\Luna Client\win32\`
- Run your application.

It is very possible to run 64-bit Luna tools (such as `lunacm`, `ckdemo`, `cmu`, `vtl`) in a Command Prompt window, while simultaneously running your 32-bit application in another Command Prompt window (using the 32-bit library by virtue of the `ChrystokiConfigurationPath` environment variable and the `crystoki.ini` file described above), and the two do not conflict, because the environments are independent. Where a problem might arise, however is if your use of the Luna tools were to make alterations to the original `crystoki.ini` file; we will call it the primary. Your application would be looking to the version of the `crystoki.ini` file in `C:\Program Files\SafeNet\Luna Client\win32\` which would not contain the changes resulting from the Luna tools; we will call that one the secondary. To correct this, you must reproduce any changes from the primary `crystoki.ini` to the secondary, before relaunching your 32-bit application.

If a tool causes a change to the configuration file, it will be to the version of the file that exists in the directory where the 64-bit Luna tools are located. In order for the change to take effect for your 32-bit application(s), you must update the copy of the configuration file in the location pointed to by the `ChrystokiConfigurationPath` environment variable, with the new or revised entries.

Examples

When setting up or modifying an NTLS connection with a Luna SA partition, the `vtl createcert`, `vtl addServer`, `vtl deleteServer`, `vtl replaceServer` commands modify the `Crystoki.ini` file and make changes to `...certs/server/CAFile.pem`. These occur in the folders associated with the 64-bit tools, and must all be replicated to the equivalent `.ini` file and folders for your 32-bit applications.

If you make any changes using `vtl`, check the file dates on `crystoki.ini` and the contents of the `certs` folders at the main LunaClient install location. If any of them have changed compared to the equivalent files at your 32-bit location, make a backup of your 32-bit Luna files, and then replace the superseded files in your 32-bit folders with the newer versions from the 64-bit folders.

Running the `stc enable` or `stc disable` commands in `lunacm` will change the `crystoki.ini` file. Update the copy that you keep in your 32-bit location to match,

Uninstalling, Modifying, or Repairing the Luna Client Software

At any time, you might need to uninstall Luna Client, or to modify the installation (perhaps to add a component or product that you did not previously install), or to repair the installed software.

To uninstall, modify, or repair the Luna client software

1. Run the **Luna Client.msi** program again. Because the software is already installed on your computer, after you click through the Welcome page, this dialog is displayed:

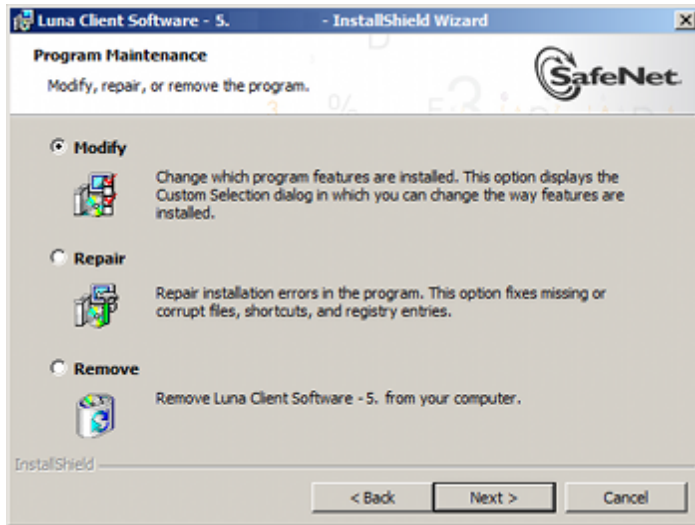

2. Choose the desired option, click **Next**, and follow the prompts. It is possible that you might see a message like this:

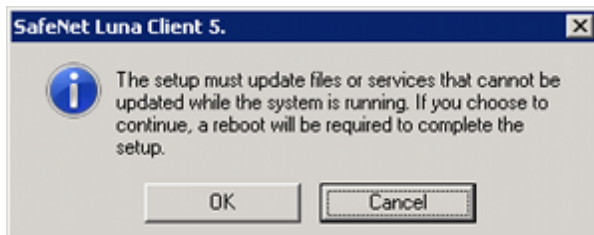

Ignore that message if you see it while uninstalling Luna Client. You do not need to restart your computer, and you will not be prompted to do so.

After Installation

When you have installed the software onto a Client, the next task is to configure the Luna HSM, as described in the *Configuration Guide*.

Open a new command-line/console window to allow the library path to be found before you run `lunacm` or other utilities that require the library.

Troubleshooting

If you are not the Administrator of the computer on which LunaClient is being installed, or if the bundle of permissions in your user profile does not allow you to launch the installer with "Run as Administrator", then some services might not install properly. One option is to have the Administrator perform the installation for you.

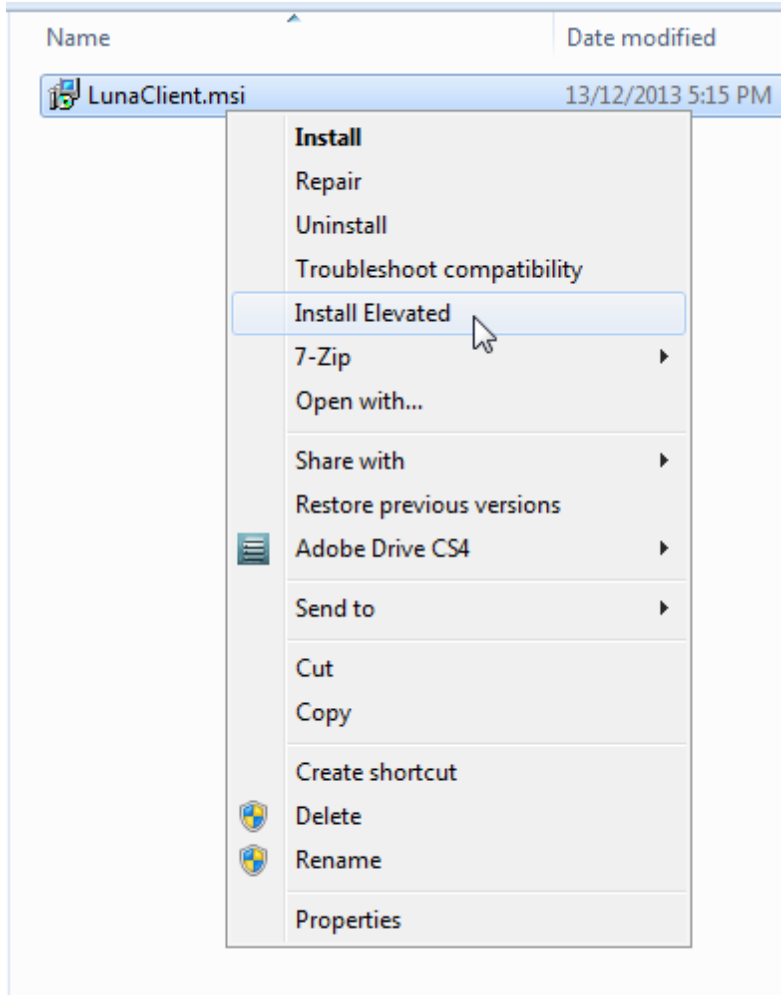

Another approach might be possible. If you have sufficient elevated permissions, you might be able to right-click and open a Command Prompt window as Administrator.

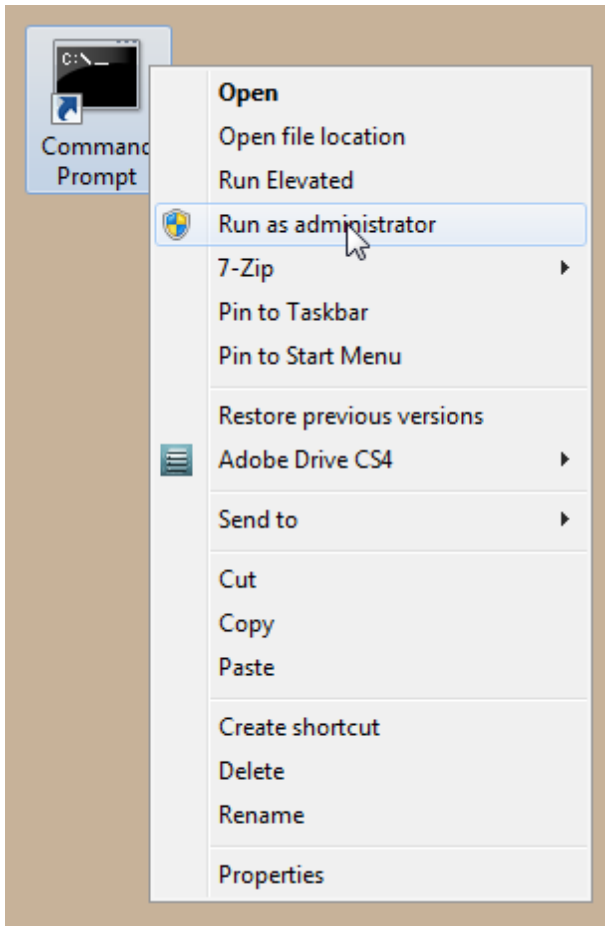

If that option is available, then you can use the command line to move to the location of the LunaClient.msi file and launch it there, which permits the needed services to load for HTL, PedClient, and other Luna features.

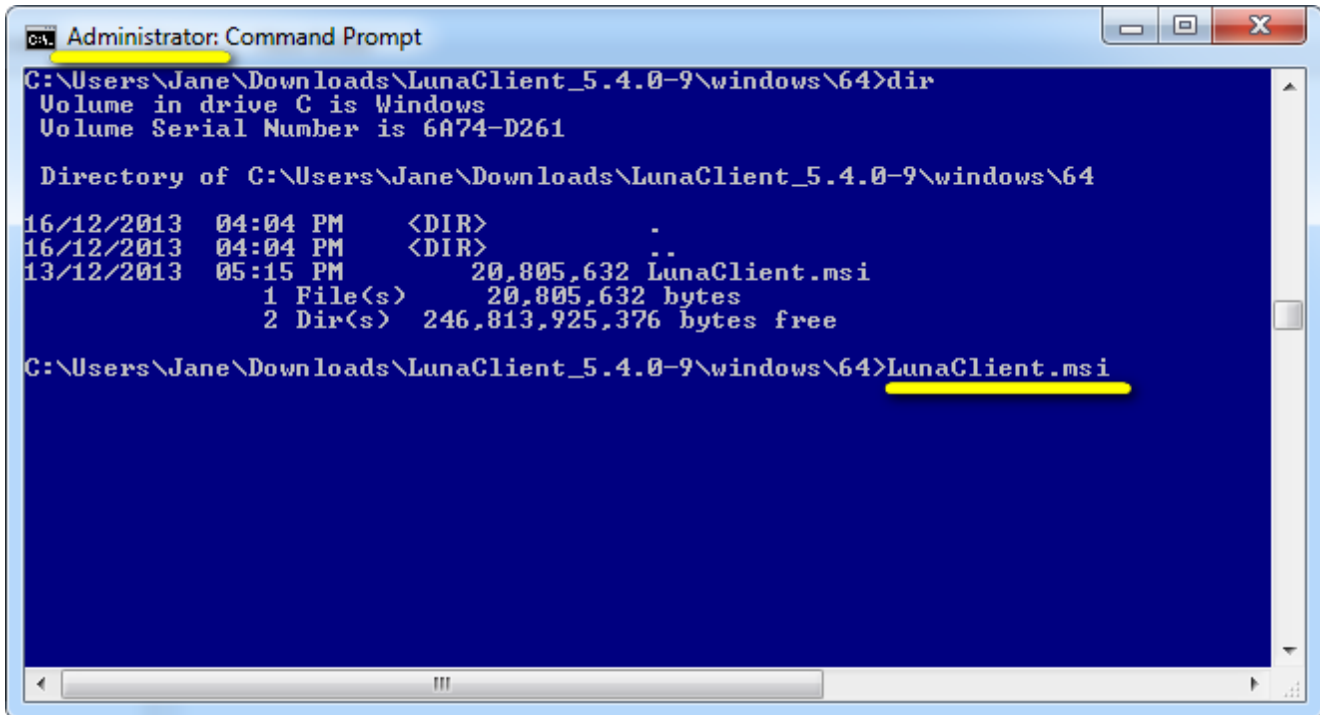

The screenshot shows a Windows Command Prompt window titled "Administrator: Command Prompt". The window has a blue background and white text. The current directory is `C:\Users\Jane\Downloads\LunaClient_5.4.0-9\windows\64`. The user has entered the `dir` command, and the output shows a directory listing with a file named `LunaClient.msi` of size 20,805,632 bytes. The user then enters `LunaClient.msi` at the prompt, which is underlined in yellow.

```
Administrator: Command Prompt
C:\Users\Jane\Downloads\LunaClient_5.4.0-9\windows\64>dir
Volume in drive C is Windows
Volume Serial Number is 6A74-D261

Directory of C:\Users\Jane\Downloads\LunaClient_5.4.0-9\windows\64

16/12/2013  04:04 PM    <DIR>          .
16/12/2013  04:04 PM    <DIR>          ..
13/12/2013  05:15 PM           20,805,632  LunaClient.msi
             1 File(s)      20,805,632 bytes
             2 Dir(s)  246,813,925,376 bytes free

C:\Users\Jane\Downloads\LunaClient_5.4.0-9\windows\64>LunaClient.msi
```

Windows 2012 Luna Client Supplemental Configuration

If you are installing the Luna client on Windows 2012, some additional configuration is required to install the .NET framework that is required for the HTL Client Service.

If your Windows Server 2012 instance is not properly configured with .NET Framework, the following alert message appears during the Luna Client installation:

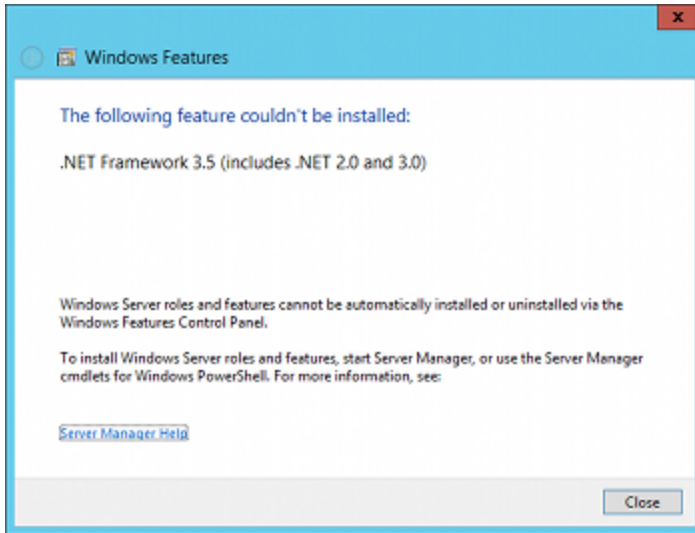

When you close the alert, a message about the HTL Client service appears.

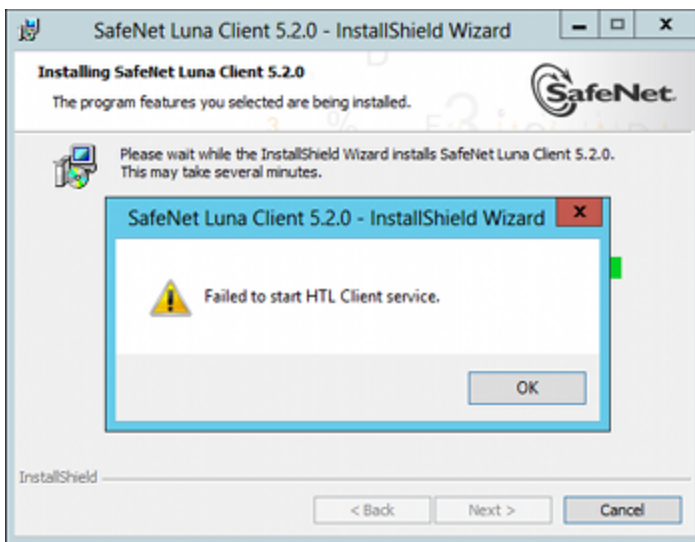

To avoid this issue, install Microsoft .NET Framework 3.5 on your Windows Server 2012 instance before you run the Luna Client 5.x installer.

Installing the .NET Framework 3.5 on Windows Server 2012

The .NET Framework 3.5 is required by the HTL Client service.

To install the .NET Framework 3.5 on Windows Server 2012

1. On your Windows Server 2012, launch **Server Manager**.

2. In Server Manager, click the **Manage** button and select **Add Roles and Features**.

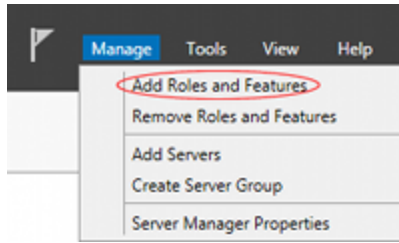

3. Configure the Add Roles and Features Wizard as follows:
 - a. Select **Role-based or feature-based** as the Installation type,
 - b. Select your server.
 - c. Check the **Application Server** role.
 - d. Click **Next**.

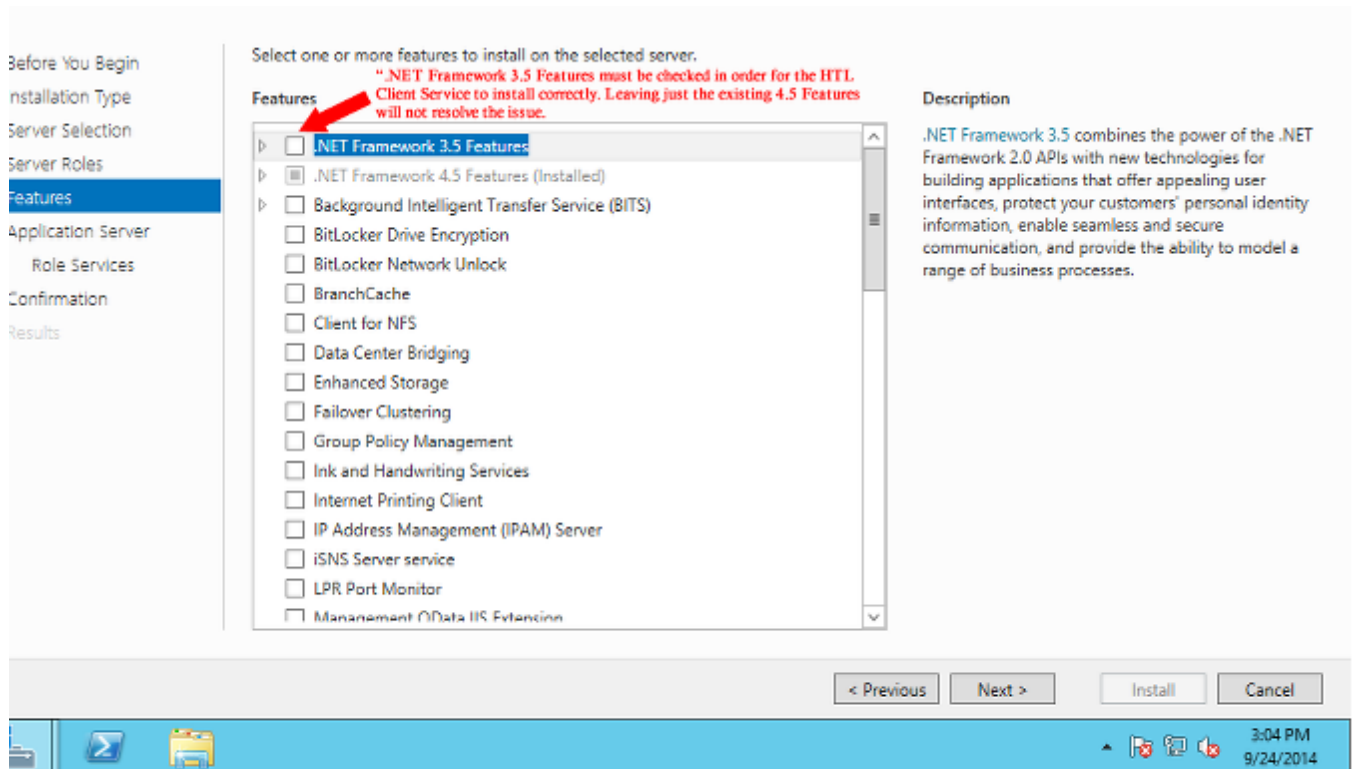

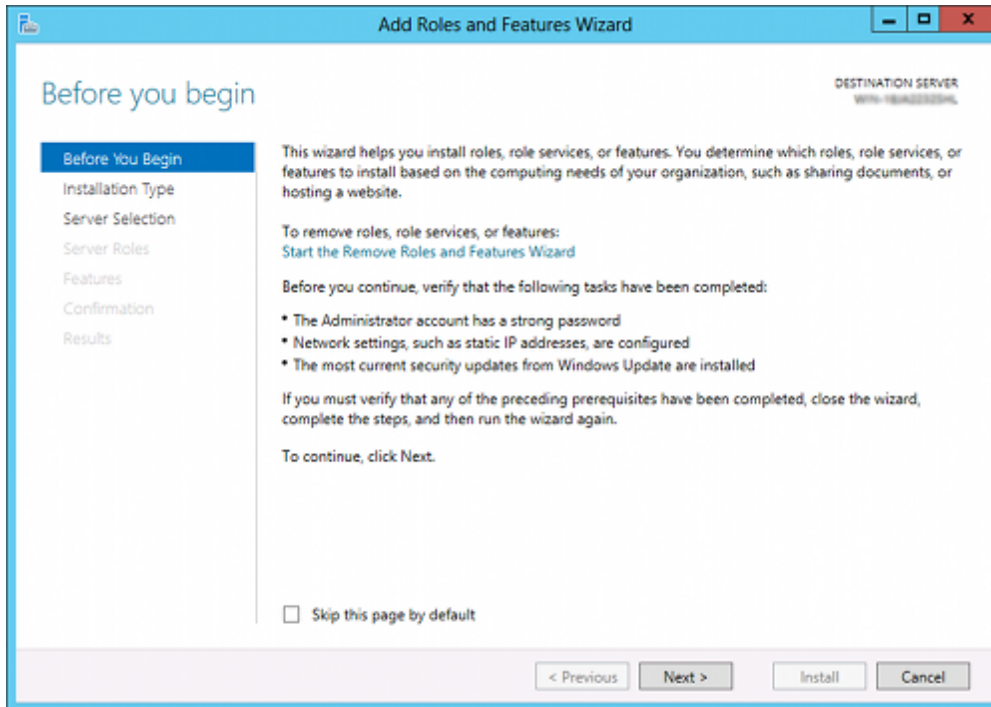

4. Click through the remaining screens to confirm your installation source and then click **Install**.
After the installation has completed, you will be able to install the Luna Client on Windows Server 2012.

Scripted / Unattended Installation on Windows

The Windows software installation section describes interactive installation on Windows systems, using the graphical, interactive installer. This section describes how to perform unattended or scripted installations on Windows platforms.

Installing the Luna Client For All Luna Products

From the location of **Luna Client.msi**, run the following command:

```
msiexec.exe /i Luna Client.msi /l lunaclient_winstall.log /quiet addlocal=all /qn
```

The setting **/l lunaclient_winstall.log** is optional and will place the installation logs into the file **lunaclient_winstall.log**.

Windows security popup on each Luna product driver install

The windows security notice (below) appears because “SafeNet, Inc.” is not among the trusted publishers on your computer:

- If you check the **Always trust software from...** checkbox and then click on the **Install** button the dialog will not appear on future installations, on that computer.
- If you do not check the **Always trust software from...** checkbox then you might see the dialog three times, once for each of the three Luna products (Luna PCI-E, Luna G5 and Luna Remote Backup HSM) that install a driver on your computer.

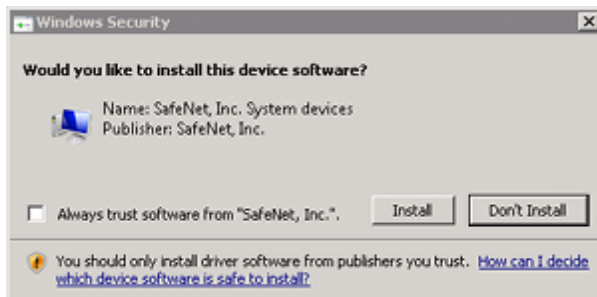

This is a Windows security requirement, introduced with Windows 2008, and is not under our control. Installing marks the publisher (in this case, SafeNet, Inc.) as trusted for future installations.

Installing the Luna Client For Luna SA

From the location of **Luna Client.msi** run the following commands:

1. Install default Luna Client components for Luna SA

```
msiexec.exe /i Luna Client.msi /l lunaclient_winstall.log /quiet addlocal=SA /qn
```

2. Install all Luna Client components for Luna SA

```
msiexec.exe /i Luna Client.msi /l lunaclient_winstall.log /quiet addlocal=SA, SA_CSP_KSP, SA_JSP, SA_SDK, SA_JCProv, SA_LDPC /qn
```

Product or component	Description
SA_CSP_KSP	Install Luna CSP and KSP components
SA_JSP	Install Luna JSP component
SA_SDK	Install Luna SDK component
SA_JCProv	Install Luna JC PROV component
SA_LDPC	Install Crypto Command Center Client component



Note: If you wish to install only some of the components, just specify the ones you want after the product name (SA in this example).



Note: The Windows security warning mentioned in section 1 (above) does not appear when only Luna SA is installed, because no driver is required. It appears only if you also install Luna PCI-E, or Luna G5, or Luna Backup HSM on the client computer.

Installing the Luna Client for Luna PCI-E

From the location of **Luna Client.msi** run the following commands:

1. Install default Luna Client components for Luna PCI-E

```
msiexec.exe /i Luna Client.msi /i lunaclient_winstall.log /quiet addlocal=PCI /qn
```

2. Install all Luna Client components for Luna PCI-E

```
msiexec.exe /i Luna Client.msi /i lunaclient_winstall.log /quiet addlocal=PCI, PCI_CSP_KSP, PCI_JSP, PCI_SDK, PCI_JCProv, PCI_SNMP /qn
```

Product or component	Description
PCI_CSP_KSP	Install Luna CSP and KSP components
PCI_JSP	Install Luna JSP component
PCI_SDK	Install Luna SDK component
PCI_JCProv	Install Luna JC PROV component
PCI_SNMP	Install Luna SNMP subagent component



Note: The Windows security warning mentioned in section 1 (above) also appears when you install Luna PCI-E, unless you have already accepted a driver installation, and therefore recognized SafeNet, Inc. as a trusted publisher.

Installing the Luna Client For Luna G5

From the location of **Luna Client.msi** run the following command:

1. Install default Luna Client components for Luna G5

```
msiexec.exe /i Luna Client.msi // lunaclient_wininstall.log /quiet addlocal=G5 /qn
```

2. Install all Luna Client components for Luna G5

```
msiexec.exe /i Luna Client.msi // lunaclient_wininstall.log /quiet addlocal=G5, G5_CSP_KSP, G5_JSP, G5_SDK, G5_JCProv, G5_SNMP /qn
```

Product or component	Description
G5_CSP_KSP	Install Luna CSP and KSP components
G5_JSP	Install Luna JSP component
G5_SDK	Install Luna SDK component
G5_JCProv	Install Luna JC PROV component
G5_SNMP	Install Luna SNMP subagent component



Note: The Windows security warning mentioned in section 1 (above) also appears when you install Luna G5, unless you have already accepted a driver installation, and therefore recognized SafeNet, Inc. as a trusted publisher.

Installing the Luna Client for Luna Remote Backup HSM

From the location of **Luna Client.msi** run the following command:

```
msiexec.exe /i Luna Client.msi // lunaclient_wininstall.log /quiet addlocal=RB, RB_SNMP /qn
```

Product or component	Description
RB_SNMP	Install Luna SNMP subagent component



Note: The Windows security mentioned in section 1 (above) also appears when you install Luna Remote Backup HSM, unless you have already accepted a driver installation, and therefore recognized SafeNet, Inc. as a trusted publisher.

Installing the Luna Client for Remote PED

From the location of **Luna Client.msi** run the following command:

```
msiexec.exe /i Luna Client.msi // lunaclient_wininstall.log /quiet addlocal=RP /qn
```



Note: When msiexec.exe is used to install Luna Client there is no message confirming that the installation has completed. The msiexec.exe utility just returns to the command line when the installation finishes.